



PARTS CATALOGUE

WR450FY'09 (5TJS) OCEANIA, SOUTH AFRICA



1H5TJ-100E1

()

WR450FY/WR450F
PARTS CATALOGUE
©2008 by Yamaha Motor Co., Ltd.
1st edition, July 2008
All rights reserved.
Any reprinting or unauthorized use
without the written permission of
Yamaha Motor Co., Ltd.
is expressly prohibited.
Printed in Japan.

FOREWORD

This Parts Catalogue is related to the parts for the model(s) on the cover page. When you are ordering replacement parts, please refer to this Parts Catalogue and quote both part numbers and part names correctly.

1. Modifications or additions which have been made after the issue of the Parts Catalogue will be announced in the Parts News.

It is advisable that you make the necessary corrections to the Parts Catalogue according to the Parts News.

2. Abbreviations

The following abbreviations are used in this Parts Catalogue.

“UR” Use specified parts number.

“UN” Use as many as needed.

“AP” Alternate Parts

“LM” Locally Made (Parts need to be ordered locally)

“F#” Frame No. (Applicable machine No.)

“O/S” Over Size

3. The number of components for assembly

- Parts, which are to be supplied in an assembly, are listed with a dot (.) in front of the part name as shown below.
- The numeral appearing to the right of each component part indicates the quantity of parts for each assembly unit.

PART NO.	DESCRIPTION	Q'TY	REMARKS
2F5-83310-60	FRONT FLASHER LIGHT ASSY	2	
115-83311-60	.BULB (6V-18W)	1	

4. Applicable colours of graphics are represented in the “REMARKS” as shown below.

PART NO.	DESCRIPTION	Q'TY	REMARKS
2N4-24110-00-X5	FUEL TANK COMP.	2	MXR
3J1-24240-10	.GRAPHIC, FUEL TANK	1	FOR MXR

5. Note that the illustrations for reference in finding parts numbers are not to be used for assembling. When assembling, please use the applicable service manual.

6. The asterisk (*) before a reference number indicates modified items after the first edition.

CONTENTS

ENGINE

CYLINDER	1
CRANKSHAFT & PISTON	2
VALVE	3
CAMSHAFT & CHAIN	5
WATER PUMP	6
RADIATOR & HOSE	7
OIL PUMP	9
OIL CLEANER	10
INTAKE	11
CARBURETOR	13
AIR INDUCTION SYSTEM	18
EXHAUST	19
CRANKCASE	20
CRANKCASE COVER 1	22
STARTER	24
STARTER CLUTCH	25
CLUTCH	26
TRANSMISSION	27
SHIFT CAM & FORK	29
SHIFT SHAFT	30

CHASSIS

FRAME	31
FENDER	33
SIDE COVER	34
REAR ARM	35
REAR SUSPENSION	37
STEERING	39
FRONT FORK	40
FUEL TANK	43
SEAT	45
FRONT WHEEL	46
FRONT BRAKE CALIPER	47
REAR WHEEL	48
REAR BRAKE CALIPER	50
STEERING HANDLE & CABLE	51
FRONT MASTER CYLINDER	52
STAND & FOOTREST	53
REAR MASTER CYLINDER	54
GENERATOR	55
STARTING MOTOR	56

METER	57
HEADLIGHT	58
TAILLIGHT	59
HANDLE SWITCH & LEVER	60
ELECTRICAL 1	61
ALTERNATE FOR CHASSIS	63

INDEX

NUMERICAL INDEX	64
-----------------------	----

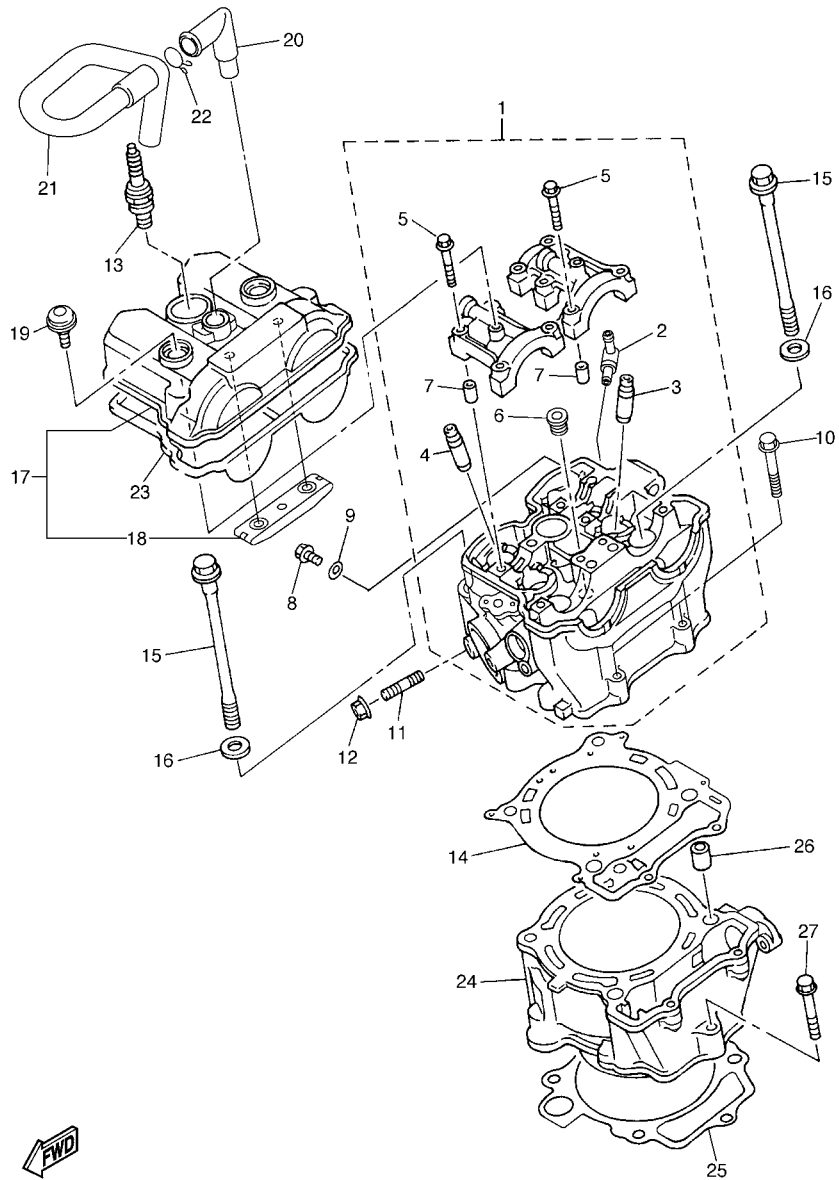

5TJE100-F010

FIG. 1 CYLINDER

REF. NO.	PART NO.	DESCRIPTION	5TJUP	5TJUR	5TJUS	REMARKS
1	5TJ-11101-10	CYLINDER HEAD ASSY	1	1	1	
2	353-13115-01	.CONNECTOR, SUCTION PIPE	1	1	1	
3	5TA-11133-10	.GUIDE, VALVE 1	3	3	3	
4	5TA-11134-10	.GUIDE, VALVE 2	2	2	2	
5	90105-06027	.BOLT, FLANGE	10	10	10	
6	90340-12007	.PLUG, STRAIGHT SCREW	1	1	1	
7	91808-16023	.PIN, DOWEL	4	4	4	
8	95022-06010	BOLT, FLANGE	1	1	1	
9	90430-06014	GASKET	1	1	1	
10	95022-06035	BOLT, FLANGE	2	2	2	
11	90116-08022	BOLT, STUD	1	1	1	
12	95702-08500	NUT, WITH WASHER	1	1	1	
13	94701-00411	PLUG, SPARK (NGK R CR8E)	1	1	1	
14	2S2-11181-00	GASKET, CYLINDER HEAD 1	1	1	1	
15	90105-10163	BOLT, FLANGE	4	4	4	
16	90201-10025	WASHER, PLATE	4	4	4	
17	2S2-11190-20	COVER, CYLINDER HEAD 1	1	1	1	
18	5BE-12241-00	.GUIDE, STOPPER 2	1	1	1	
19	5UM-1119E-00	BOLT, COVER HEAD	2	2	2	
20	3P6-11167-00	PIPE, BREATHER 2	1	1	1	
21	5TJ-11166-10	PIPE, BREATHER 1	1	1	1	
22	90467-160A4	CLIP	1	1	1	
23	2S2-11193-00	GASKET, HEAD COVER 1	1	1	1	
24	2S2-11311-10	CYLINDER 1	1	1	1	
25	2S2-11351-00	GASKET, CYLINDER	1	1	1	
26	93612-16254	PIN, DOWEL	2	2	2	
27	95022-06035	BOLT, FLANGE	1	1	1	

FIG. 2 CRANKSHAFT & PISTON

REF. NO.	PART NO.	DESCRIPTION	5TJUP	5TJUF	5TJUS	REMARKS
1	5TJ-11400-20	CRANKSHAFT ASSY	1	1	1	
2	5TJ-11412-20	.CRANK 1	1	1	1	
3	2S2-11422-00	.CRANK 2	1	1	1	
4	5TG-11681-00	.PIN, CRANK 1	1	1	1	
5	93310-63417	.BEARING	1	1	1	
6	2S2-11651-00	.ROD, CONNECTING	1	1	1	
7	93306-30633	BEARING	2	2	2	
8	2S2-11536-00	GEAR, DRIVE	1	1	1	
9	2S2-11455-00	SHAFT 1	1	1	1	
10	93304-20310	BEARING	2	2	2	
11	2S2-11531-00	GEAR, BALANCE WEIGHT	1	1	1	
12	90170-14171	NUT	1	1	1	
13	90215-14287	WASHER, LOCK	1	1	1	
14	2S2-11454-00	WEIGHT 1	1	1	1	
15	90149-06083	SCREW	3	3	3	
16	2S2-11464-00	WEIGHT 2	1	1	1	
17	90282-05034	KEY, STRAIGHT	1	1	1	
18	90170-10405	NUT	1	1	1	
19	90215-10009	WASHER, LOCK	1	1	1	
20	90280-03006	KEY, WOODRUFF	1	1	1	
21	2S2-11631-20	PISTON (STD)	1	1	1	
22	5JG-11603-00	PISTON RING SET (STD)	1	1	1	
23	5TA-11633-00	PIN, PISTON	1	1	1	
24	93420-18082	CIRCLIP	2	2	2	

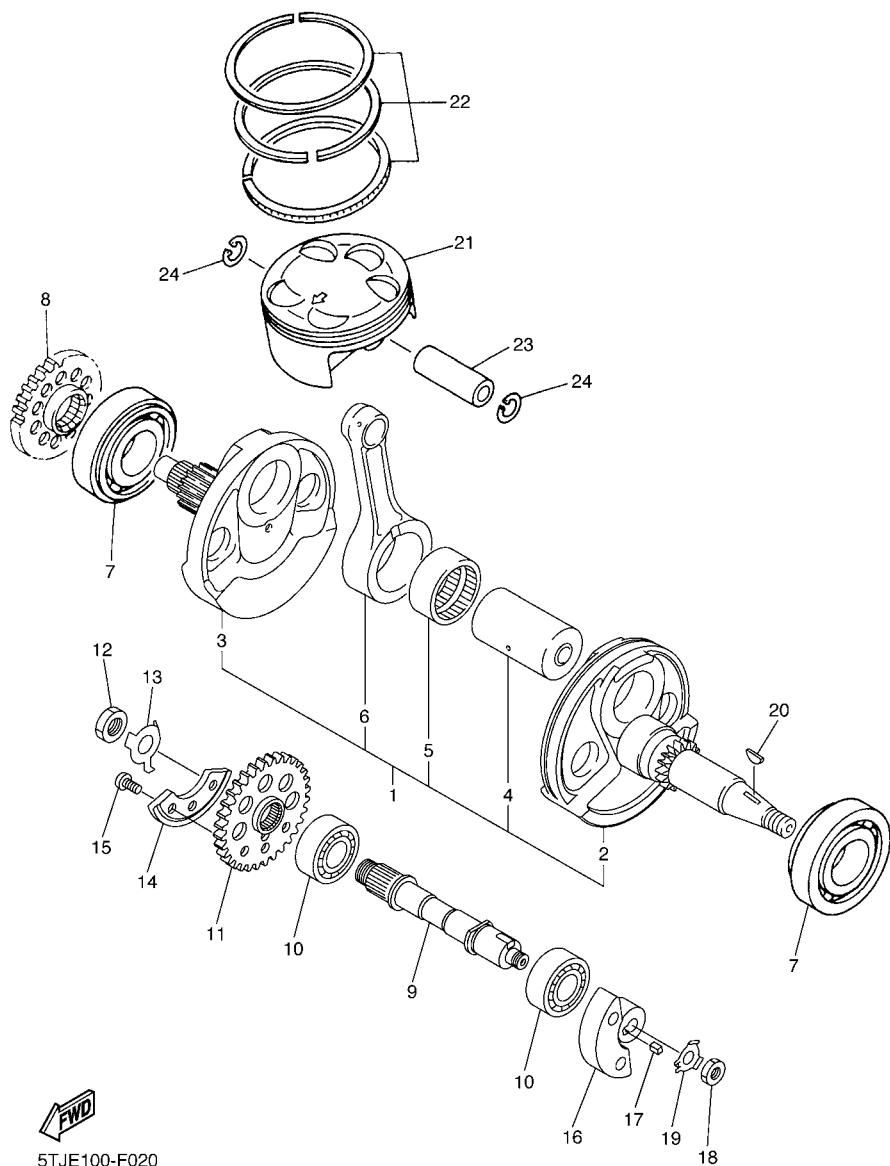

5TJE100-F020

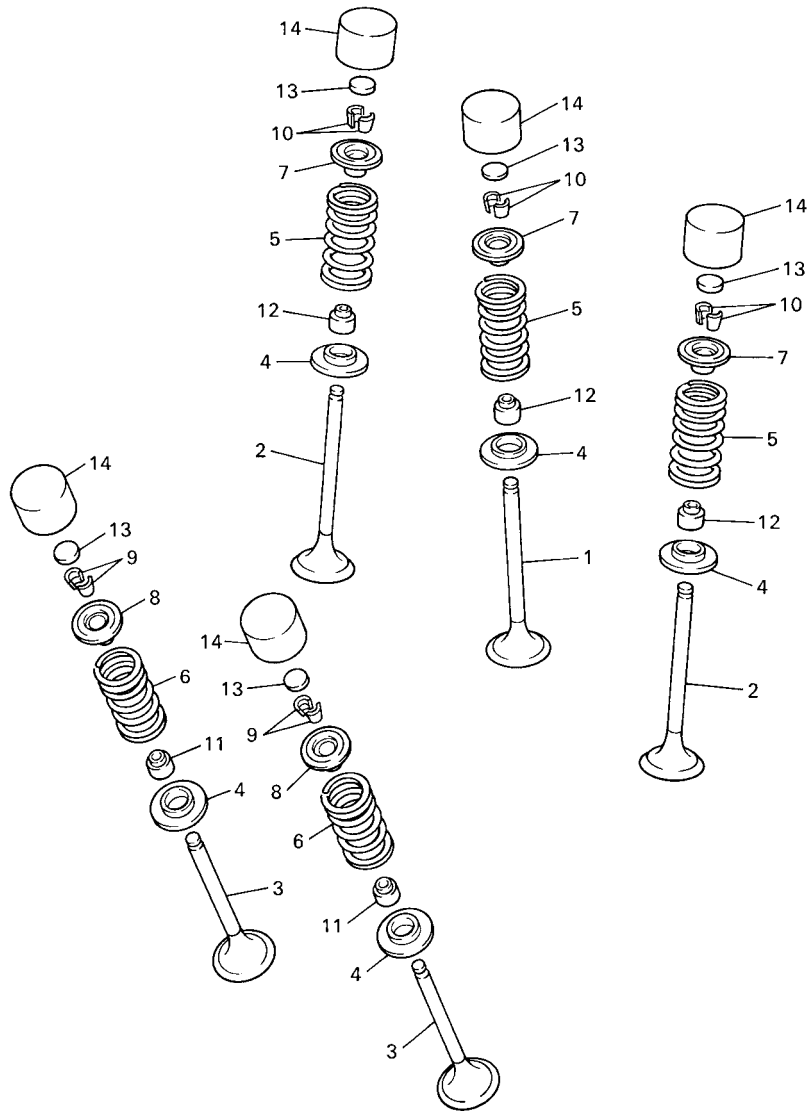

5BE100-8030

FIG. 3 VALVE

REF. NO.	PART NO.	DESCRIPTION	5TUP	5TUR	5TUS	REMARKS
1	5TA-12111-00	VALVE, INTAKE	1	1	1	
2	5TA-12112-00	VALVE, INTAKE 2	2	2	2	
3	5TA-12121-00	VALVE, EXHAUST	2	2	2	
4	3GM-12126-00	SEAT, VALVE SPRING 2	5	5	5	
5	5TJ-12113-00	SPRING, VALVE INNER	3	3	3	
6	5TJ-12114-00	SPRING, VALVE OUTER	2	2	2	
7	5BE-12117-00	RETAINER, VALVE SPRING	3	3	3	
8	4GY-12117-00	RETAINER, VALVE SPRING	2	2	2	
9	1AA-12118-00	COTTER, VALVE	4	4	4	
10	1WG-12118-00	COTTER, VALVE	6	6	6	
11	33M-12119-00	SEAL, VALVE STEM	2	2	2	
12	4SV-12119-00	SEAL, VALVE STEM	3	3	3	
13	3LD-12168-00	PAD, ADJUSTING (1.20)	5	5	5	UR
	3LD-12168-20	PAD, ADJUSTING (1.25)	5	5	5	UR
	3LD-12168-40	PAD, ADJUSTING (1.30)	5	5	5	UR
	3LD-12168-60	PAD, ADJUSTING (1.35)	5	5	5	UR
	3LD-12168-80	PAD, ADJUSTING (1.40)	5	5	5	UR
	3LD-12168-A0	PAD, ADJUSTING (1.45)	5	5	5	UR
	3LD-12168-F0	PAD, ADJUSTING (1.50)	5	5	5	UR
	3LD-12168-H1	PAD, ADJUSTING (1.55)	5	5	5	UR
	3LD-12168-K1	PAD, ADJUSTING (1.60)	5	5	5	UR
	3LD-12168-M1	PAD, ADJUSTING (1.65)	5	5	5	UR
	3LD-12168-R1	PAD, ADJUSTING (1.70)	5	5	5	UR
	3LD-12168-U1	PAD, ADJUSTING (1.75)	5	5	5	UR
	3LD-12168-W1	PAD, ADJUSTING (1.80)	5	5	5	UR
	3LD-12168-Y1	PAD, ADJUSTING (1.85)	5	5	5	UR
	3LD-12169-11	PAD, ADJUSTING (1.90)	5	5	5	UR

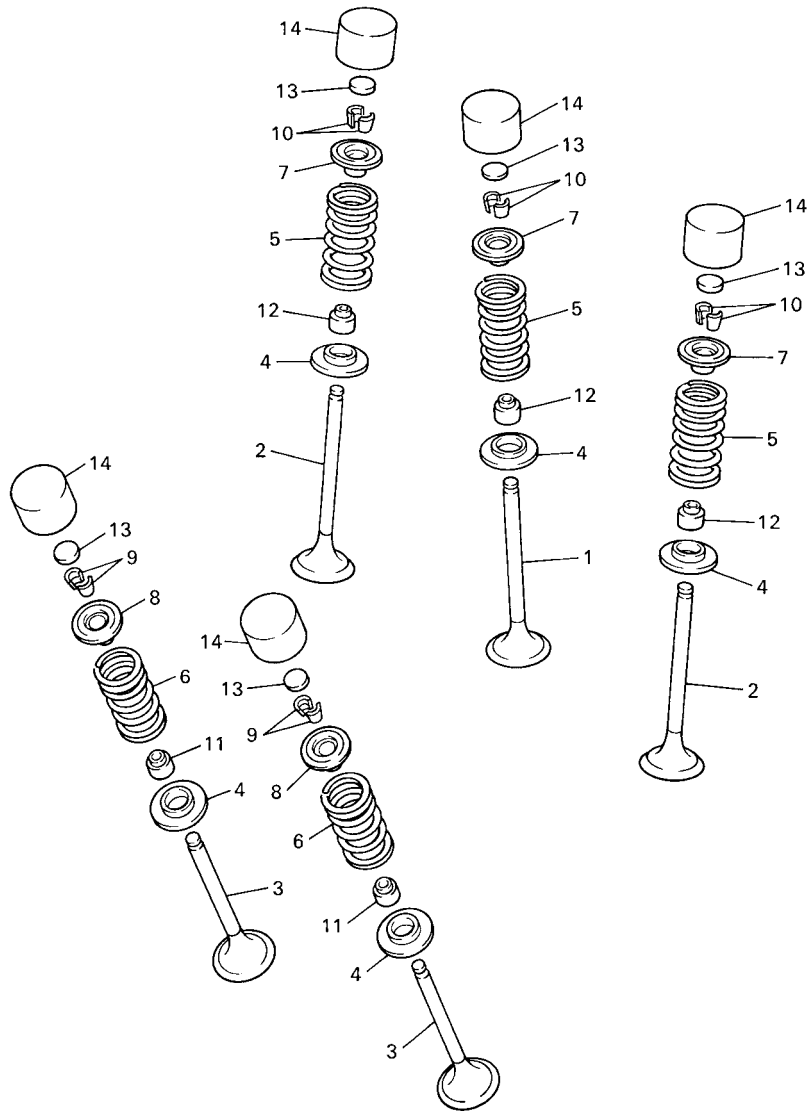

5BE100-8030

FIG. 3 VALVE

REF. NO.	PART NO.	DESCRIPTION	STUP	STUR	STUS	REMARKS
13	3LD-12169-31	PAD, ADJUSTING (1.95)	5	5	5	UR
	3LD-12169-50	PAD, ADJUSTING (2.00)	5	5	5	UR
	3LD-12169-70	PAD, ADJUSTING (2.05)	5	5	5	UR
	3LD-12169-90	PAD, ADJUSTING (2.10)	5	5	5	UR
	3LD-12169-E0	PAD, ADJUSTING (2.15)	5	5	5	UR
	3LD-12169-G0	PAD, ADJUSTING (2.20)	5	5	5	UR
	3LD-12169-J0	PAD, ADJUSTING (2.25)	5	5	5	UR
	3LD-12169-L0	PAD, ADJUSTING (2.30)	5	5	5	UR
	3LD-12169-N0	PAD, ADJUSTING (2.35)	5	5	5	UR
	3LD-12169-T0	PAD, ADJUSTING (2.40)	5	5	5	UR
14	3FV-12153-10	LIFTER, VALVE	5	5	5	YELLOW

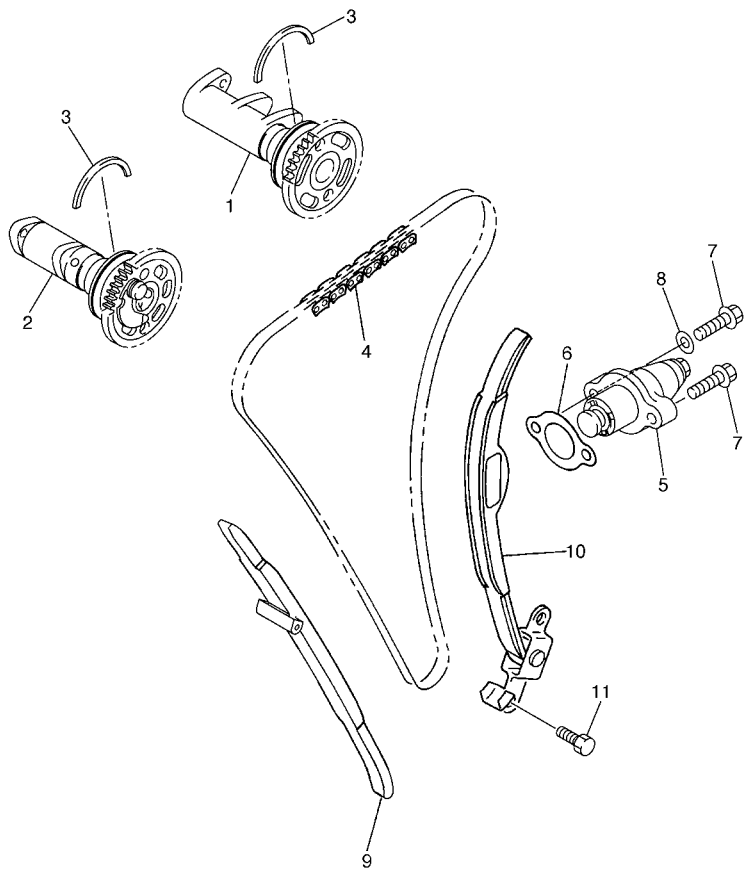
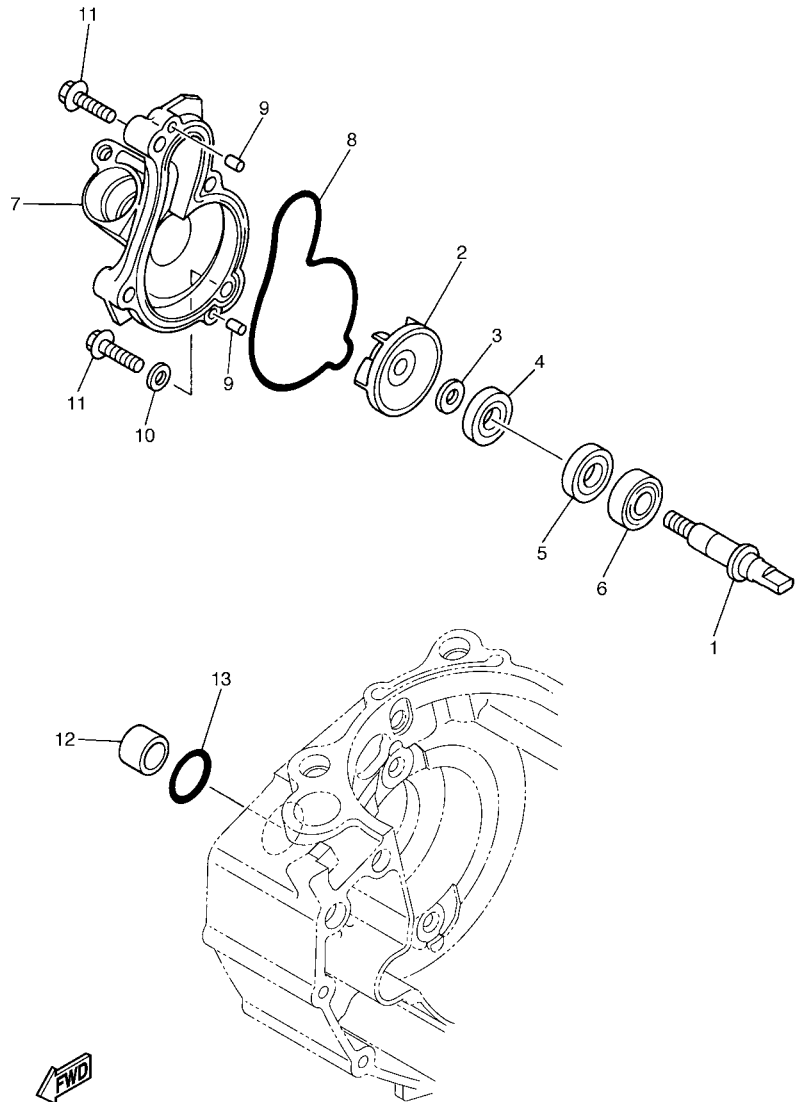

FIG. 4 CAMSHAFT & CHAIN

REF. NO.	PART NO.	DESCRIPTION	5TJF	5TJR	5TJS	REMARKS
1	5TJ-12170-00	CAMSHAFT ASSY 1	1	1	1	
2	5TJ-12180-30	CAMSHAFT ASSY 2	1	1	1	
3	93440-41178	CIRCLIP	2	2	2	
4	94591-57118	CHAIN (98XRH2010-118M)	1	1	1	
5	5TA-12210-10	TENSIONER ASSY, CAM CHAIN	1	1	1	
6	4FM-12213-00	GASKET, TENSIONER CASE	1	1	1	
7	95022-06025	BOLT, FLANGE	2	2	2	
8	90430-06014	GASKET	1	1	1	
9	2S2-12251-00	DAMPER, CHAIN 1	1	1	1	
10	5TA-12252-00	DAMPER, CHAIN 2	1	1	1	
11	5TJ-12299-00	BOLT, STOPPER	2	2	2	

FIG. 5 WATER PUMP



2S21100-E050

REF. NO.	PART NO.	DESCRIPTION	5TUP	5TJR	5TJS	REMARKS
1	5GR-12458-00	SHAFT, IMPELLER	1	1	1	
2	5DJ-12451-00	IMPELLER, WATER PUMP	1	1	1	
3	90201-08512	WASHER, PLATE	1	1	1	
4	93109-11073	OIL SEAL	1	1	1	
5	93102-12106	OIL SEAL (SD 12-22-5 HS)	1	1	1	
6	93306-00105	BEARING	1	1	1	
7	5BE-12422-20	COVER, HOUSING	1	1	1	
8	5BE-12439-00	O-RING	1	1	1	
9	93604-10011	PIN, DOWEL	2	2	2	
10	90430-06014	GASKET	1	1	1	
11	95022-06030	BOLT, FLANGE	4	4	4	
12	5BE-12564-00	PIPE, WATER	1	1	1	
13	93210-19758	O-RING	1	1	1	

FIG. 6 RADIATOR & HOSE

REF. NO.	PART NO.	DESCRIPTION	5TJF	5TJF	5TJUS	REMARKS
1	5TJ-1240A-E0	RADIATOR ASSY	1	1	1	
2	2S2-12464-70	.STAY, RADIATOR	1	1	1	
3	92012-06010	.BOLT, BUTTON HEAD	3	3	3	
4	90183-060A6	.NUT, SPRING	1	1	1	
5	2S2-12461-70	RADIATOR ASSY	1	1	1	
6	2S2-12464-70	.STAY, RADIATOR	1	1	1	
7	92012-06010	.BOLT, BUTTON HEAD	3	3	3	
8	90183-060A6	.NUT, SPRING	1	1	1	
9	22W-12462-00	CAP, RADIATOR	1	1	1	
10	91A20-05140	TUBE, FLEXIBLE VINYL	1	1	1	
11	90467-090A2	CLIP	1	1	1	
12	2S2-12481-00	PIPE 1	1	1	1	
13	91312-06012	BOLT	1	1	1	
14	93210-16500	O-RING	1	1	1	
15	2S2-12576-00	HOSE 1	1	1	1	
16	1C3-12482-00	PIPE 2	1	1	1	
17	2S2-12578-00	HOSE 3	1	1	1	
18	5TJ-12579-E0	HOSE 4	1	1	1	
19	2S2-12482-00	PIPE 2	1	1	1	
20	95022-06012	BOLT, FLANGE	1	1	1	
21	93210-16500	O-RING	1	1	1	
22	90450-28001	HOSE CLAMP ASSY	3	3	3	
23	90450-25001	HOSE CLAMP ASSY	3	3	3	
24	90450-22001	HOSE CLAMP ASSY	2	2	2	
25	90480-15528	GROMMET	4	4	4	
26	90387-06065	COLLAR	4	4	4	
27	90105-06111	BOLT, FLANGE	4	4	4	

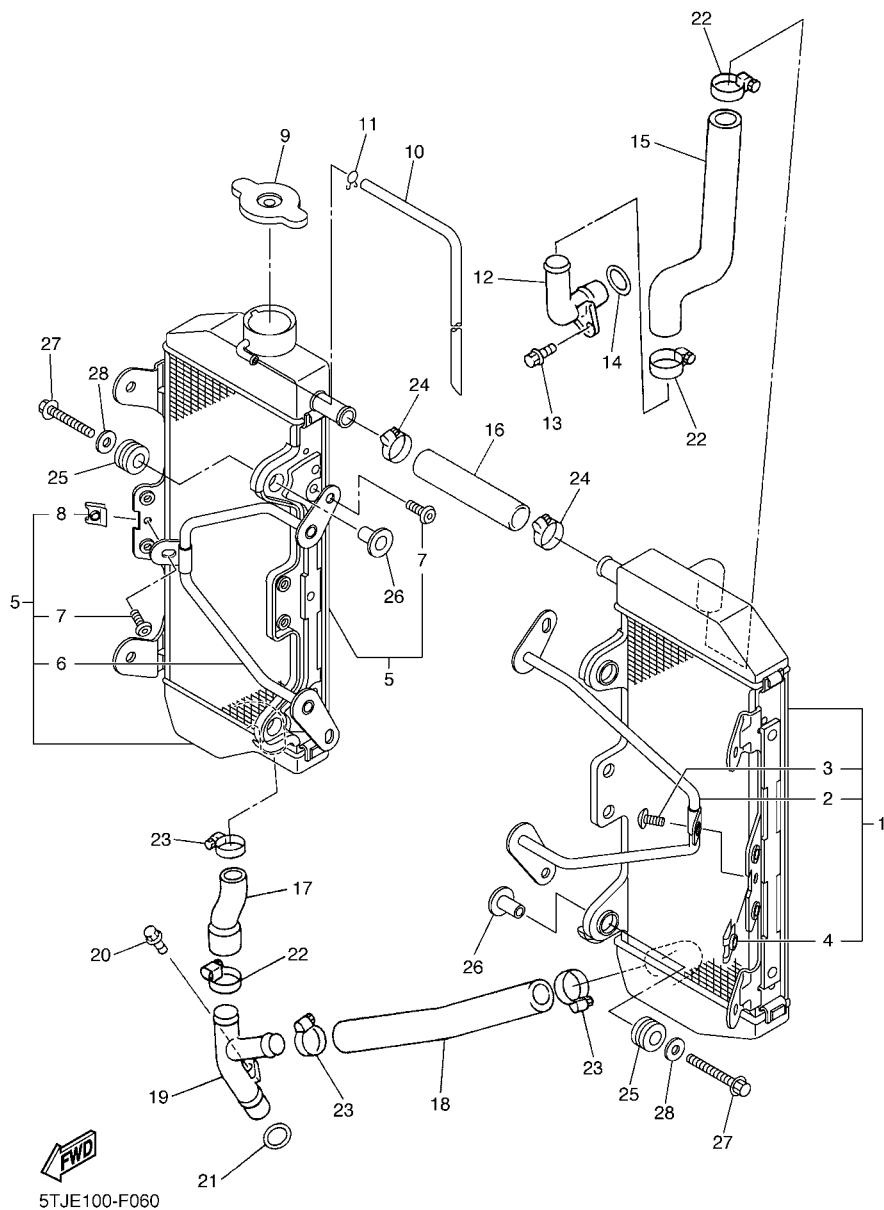



2S21100-E070

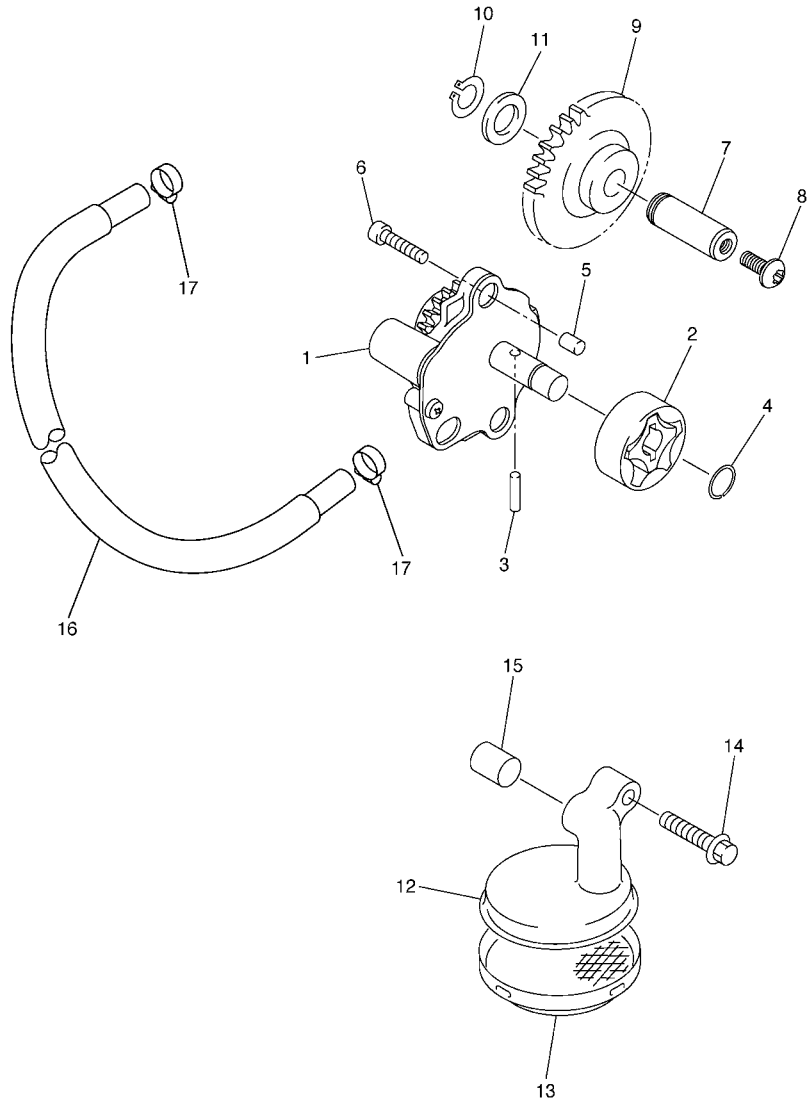

FIG. 7 OIL PUMP

REF. NO.	PART NO.	DESCRIPTION	STUP	STUR	STUS	REMARKS
1	2S2-13300-10	OIL PUMP ASSY	1	1	1	
2	5TA-13320-00	ROTOR ASSY 2	1	1	1	
3	93603-16219	PIN, DOWEL	1	1	1	
4	93440-10153	CIRCLIP	1	1	1	
5	99530-08012	PIN, DOWEL	2	2	2	
6	91312-06030	BOLT	2	2	2	
7	2S2-13342-00	SHAFT, IDLE GEAR	1	1	1	
8	90149-06068	SCREW	1	1	1	
9	2S2-13341-00	GEAR, OIL PUMP IDLE	1	1	1	
10	99009-12400	CIRCLIP	1	1	1	
11	90201-12166	WASHER, PLATE	1	1	1	
12	2S2-13412-00	HOUSING, STRAINER	1	1	1	
13	5BE-13411-00	STRAINER, OIL	1	1	1	
14	95022-06030	BOLT, FLANGE	1	1	1	
15	99530-10114	PIN, DOWEL	1	1	1	
16	90445-14009	HOSE	1	1	1	
17	90450-17001	HOSE CLAMP ASSY	2	2	2	

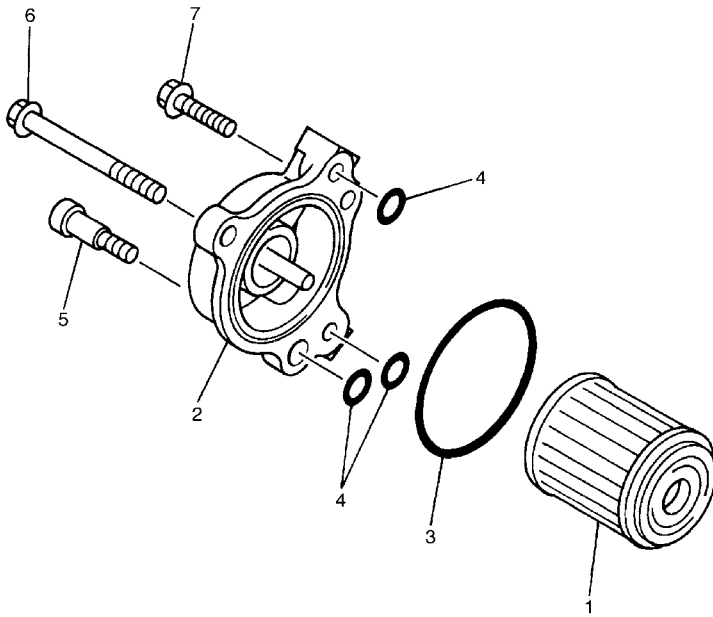

FIG. 8 OIL CLEANER

REF. NO.	PART NO.	DESCRIPTION	STUP	STUR	STUS	REMARKS
1	5D3-13440-00	ELEMENT ASSY, OIL CLEANER	1	1	1	
2	5BE-13447-20	COVER, OIL ELEMENT	1	1	1	
3	93210-47675	O-RING	1	1	1	
4	93210-07135	O-RING	3	3	3	
5	90110-06228	BOLT, HEXAGON SOCKET HEAD	1	1	1	
6	91312-06065	BOLT	1	1	1	
7	91312-06020	BOLT	1	1	1	

 2S21100-E080

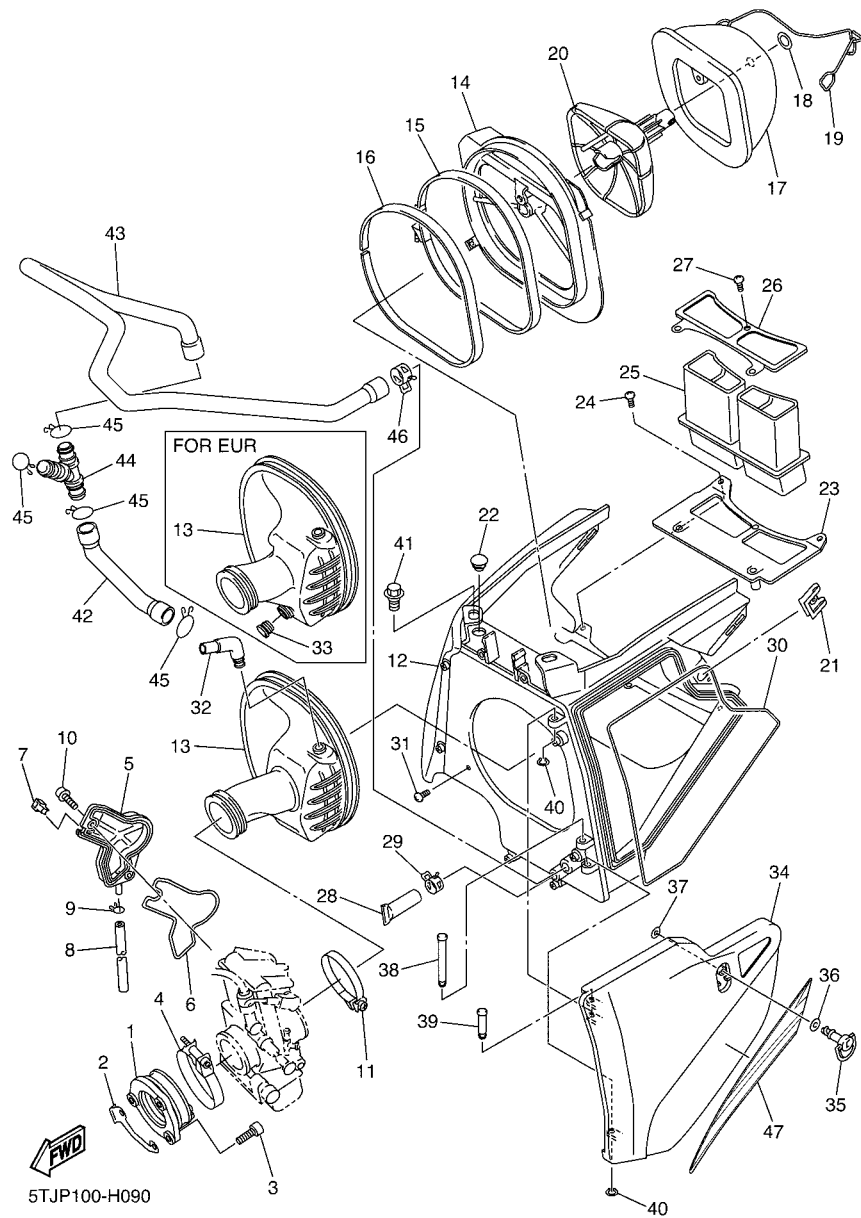

FIG. 9 INTAKE

REF. NO.	PART NO.	DESCRIPTION	5TJP	5TJR	5TJS	REMARKS
1	2S2-13597-00	JOINT, CARBURETOR 3	1	1	1	
2	5TJ-14291-00	BRACKET 1	1	1	1	
3	91312-06020	BOLT	3	3	3	
4	90450-57010	HOSE CLAMP ASSY	1	1	1	
5	5TA-14293-00	COVER 1	1	1	1	
6	5TA-14227-00	GASKET	1	1	1	
7	5TA-14239-00	SEAL	1	1	1	
8	5TA-14987-00	HOSE	1	1	1	
9	3TJ-14137-40	CLIP	1	1	1	
10	90110-05038	BOLT, HEXAGON SOCKET HEAD	2	2	2	
11	90450-61002	HOSE CLAMP ASSY	1	1	1	
12	5UM-14401-E0	AIR CLEANER CASE ASSY	1	1	1	
13	5TJ-14453-E0	JOINT, AIR CLEANER 1	1		1	
14	5TJ-14459-01	HOLDER, GUIDE	1	1	1	
15	5NY-14455-20	BAND	1	1	1	
16	5NY-14442-00	SPACER	1	1	1	
17	5UM-14451-E0	ELEMENT, AIR CLEANER	1	1	1	
18	5TJ-14475-00	WASHER	1	1	1	
19	5UM-1441G-E0	BINDER 1	1	1	1	
20	5TJ-14458-00	GUIDE	1	1	1	
21	4XV-2177L-01	PLATE, SPRING	1	1	1	
22	90338-07043	PLUG	1	1	1	
23	5UM-14437-E0	DUCT	1	1	1	
24	97702-50516	SCREW, TAPPING	2	2	2	
25	5UM-1443A-E0	DUCT	1	1	1	
26	5UM-14417-E0	COVER 1	1	1	1	

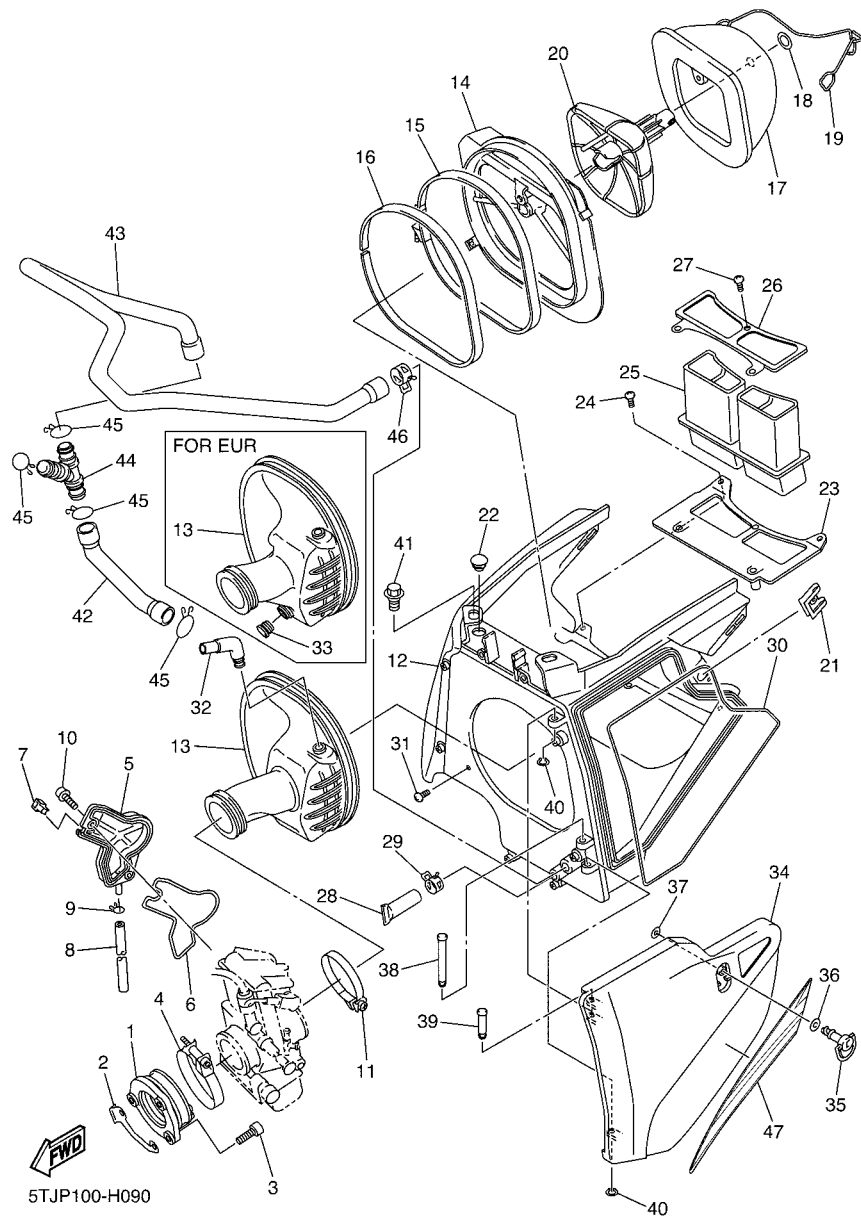

FIG. 9 INTAKE

REF. NO.	PART NO.	DESCRIPTION	5TJP	5TJR	5TJS	REMARKS
27	97702-50516	SCREW, TAPPING	3	3	3	
28	5BF-1443E-00	PIPE, DRAIN	1	1	1	
29	90467-17089	CLIP	1	1	1	
30	5UM-14462-E0	SEAL	1	1	1	
31	97702-50516	SCREW, TAPPING	1	1	1	
32	5TJ-14419-00	PIPE	1	1	1	
34	5UM-1441A-E0	COVER, CLEANER CASE 1	1	1	1	
35	3FV-28386-00	HEAD	1	1	1	
36	2TK-21757-00	WASHER, SPECIAL 1	1	1	1	
37	5TJ-21757-00	WASHER, SPECIAL 1	1	1	1	
38	90249-05005	PIN	1	1	1	
39	90249-05004	PIN	1	1	1	
40	99002-04600	CIRCLIP	2	2	2	
41	90109-06245	BOLT	2	2	2	
42	5TJ-11167-10	PIPE, BREATHER 2	1	1	1	
43	5TJ-11126-00	PIPE, BREATHER 3	1	1	1	
44	90413-14001	WAY 3	1	1	1	
45	90467-160A4	CLIP	4	4	4	
46	90467-17089	CLIP	1	1	1	
47	5TJ-2165C-10	GRAPHIC 1	1	1	1	

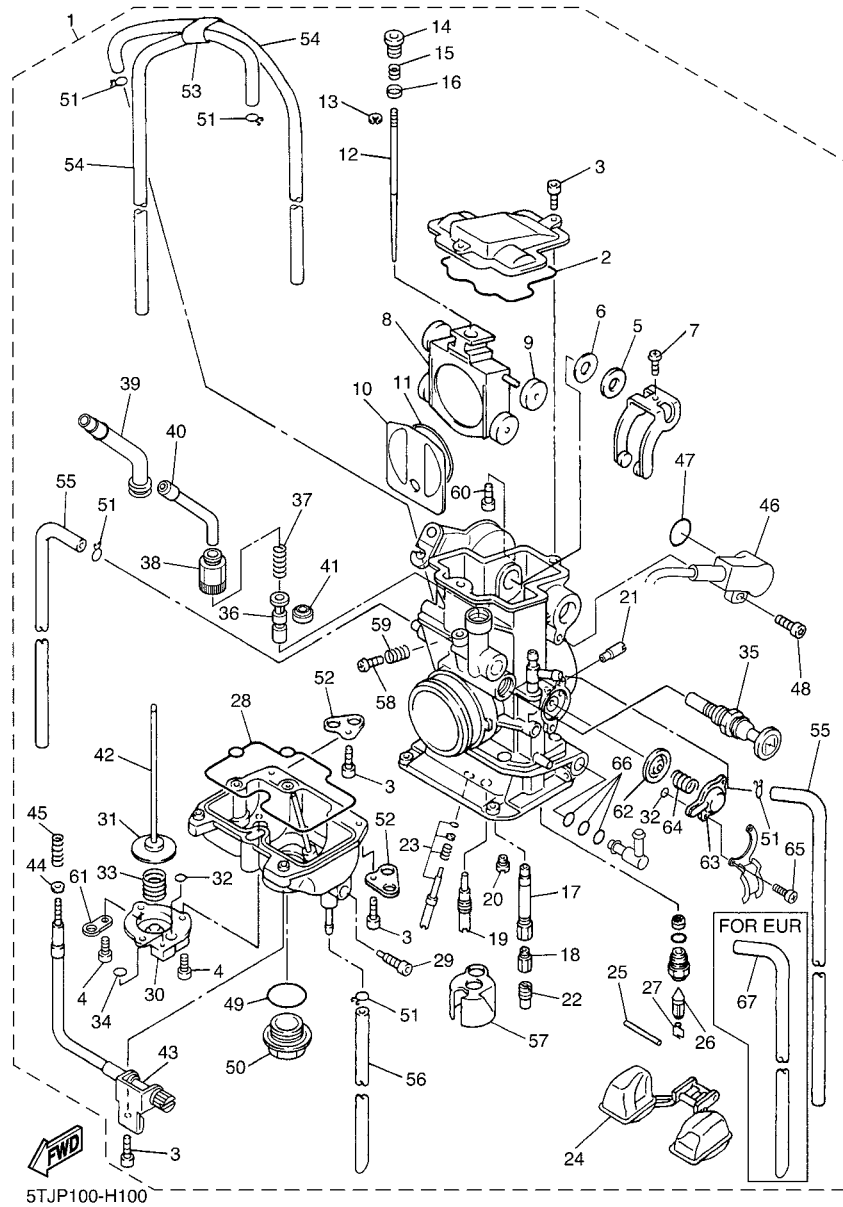

FIG. 10 CARBURETOR

REF. NO.	PART NO.	DESCRIPTION	5TJP	5TJR	5TJS	REMARKS
1	5TJ-14101-E0	CARBURETOR ASSY 1	1		1	
2	5JG-14959-00	.GASKET	1	1	1	
3	91316-04012	.BOLT	6	6	6	
4	688-14592-00	.SCREW	3	3	3	
5	90202-08045	.WASHER, PLATE	1	1	1	
6	5JG-14951-00	.WASHER	1	1	1	
7	5JG-14522-00	.SCREW, ADJUST	1	1	1	
8	2S2-14388-00	.VALVE, VACUUM CONTROL	1	1	1	
9	3TJ-14267-40	.ROLLER	1	1	1	
10	5JG-14546-01	.VALVE, NEEDLE	1	1	1	
11	4FN-14997-00	.SEAL	1	1	1	
12	5TJ-14916-NT	.NEEDLE (NFNT)	1		1	STD
	5TJ-14916-LU	.NEEDLE (NNHU)		1		STD
	5TJ-14916-AM	.NEEDLE (GDDSM)			1	AP
	5TJ-14916-AN	.NEEDLE (GDDSN)			1	AP
	5TJ-14916-AP	.NEEDLE (GDDSP)			1	AP
	5TJ-14916-A1	.NEEDLE (GDDSQ)			1	AP
	5TJ-14916-AR	.NEEDLE (GDDSR)			1	AP
	5TJ-14916-AS	.NEEDLE (GDDSS)			1	AP

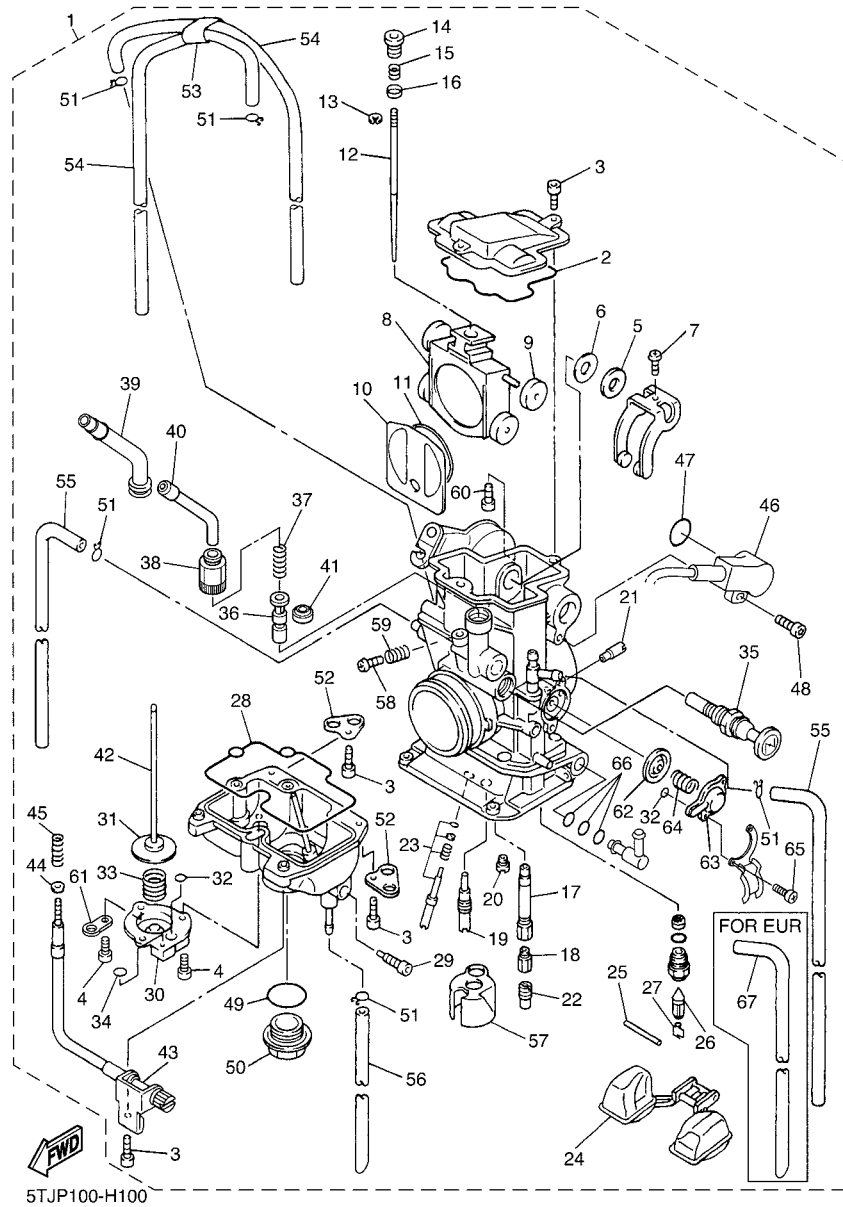
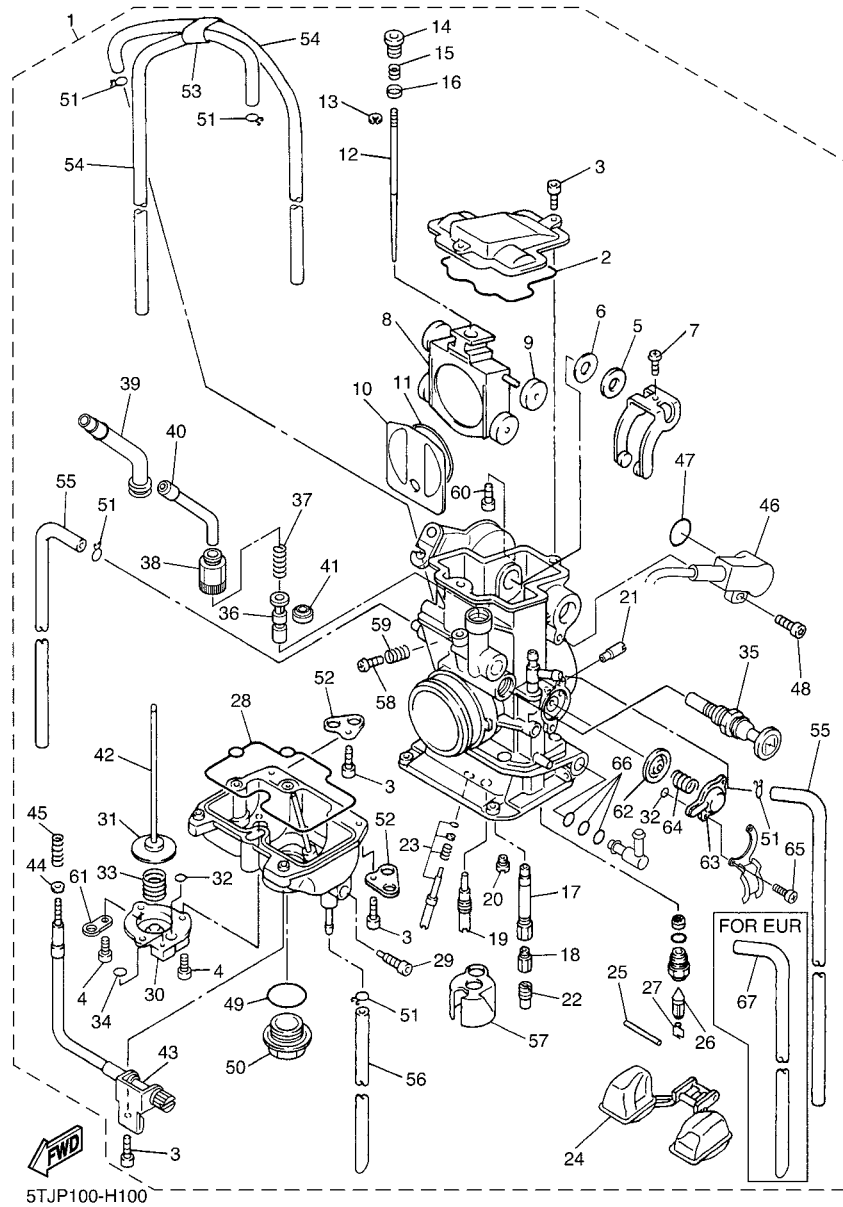

FIG. 10 CARBURETOR

REF. NO.	PART NO.	DESCRIPTION	5TJP	5TJR	5TJS	REMARKS
12	5TJ-14916-AT	.NEEDLE (GDDST)			1	AP
13	3TJ-14159-40	.CLIP	1	1	1	
14	5JG-14521-00	.SCREW, ADJUST	1	1	1	
15	5JG-14275-00	.SPRING	1	1	1	
16	5JG-14264-00	.COLLAR	1	1	1	
17	5TJ-14947-00	.JET, NEEDLE	1	1	1	
18	4MX-14943-90	.JET, MAIN (#162)	1		1	STD
	4MX-14943-39	.JET, MAIN (#160)		1		STD
	4MX-14943-90	.JET, MAIN (#162)		1		AP
	4MX-14943-40	.JET, MAIN (#165)		1	1	AP
	4MX-14943-91	.JET, MAIN (#168)		1	1	AP
	4MX-14943-41	.JET, MAIN (#170)		1	1	AP
	4MX-14943-92	.JET, MAIN (#172)		1	1	AP
	4MX-14943-42	.JET, MAIN (#175)		1	1	AP
	4MX-14943-93	.JET, MAIN (#178)		1	1	AP
	4MX-14943-43	.JET, MAIN (#180)		1	1	AP
	4MX-14943-94	.JET, MAIN (#182)		1	1	AP
	4MX-14943-44	.JET, MAIN (#185)		1	1	AP
19	4MX-14948-05	.JET, SLOW (#45)	1		1	STD
	4MX-14948-06	.JET, SLOW (#48)			1	AP
	4MX-14948-07	.JET, SLOW (#50)		1	1	AP
	4MX-14948-08	.JET, SLOW (#52)		1	1	AP
	4MX-14948-09	.JET, SLOW (#55)		1	1	AP
20	3TJ-1494F-13	.JET (#65)	1	1	1	STD
	3TJ-1494F-11	.JET (#60)		1	1	AP



5TJP100-H100

FIG. 10 CARBURETOR

REF. NO.	PART NO.	DESCRIPTION	5TJP	5TJR	5TJS	REMARKS
20	3TJ-1494F-12	.JET (#62)		1	1	AP
	3TJ-1494F-14	.JET (#68)		1	1	AP
	3TJ-1494F-15	.JET (#70)		1	1	AP
21	5TA-14943-15	.JET, MAIN (#70)	1	1	1	
22	4JT-1494F-11	.JET (#60)	1	1	1	STD
	4JT-1494F-01	.JET (#35)		1	1	AP
	4JT-1494F-03	.JET (#40)		1	1	AP
	4JT-1494F-05	.JET (#45)		1	1	AP
	4JT-1494F-07	.JET (#50)		1	1	AP
	4JT-1494F-09	.JET (#55)		1	1	AP
	4JT-1494F-13	.JET (#65)		1	1	AP
23	5NL-14105-00	.PILOT SCREW SET	1	1	1	
24	4SR-14985-00	.FLOAT	1	1	1	
25	676-14548-00	.PIN, FLOAT ARM	1	1	1	
26	4MX-14392-00	.VALVE, NEEDLE	1	1	1	
27	633-14159-00	.CLIP	1	1	1	
28	5JG-14984-00	.GASKET, FLOAT CHAMBER	1	1	1	
29	3TJ-14191-40	.PLUG, DRAIN	1	1	1	
30	3TJ-14293-40	.COVER 1	1	1	1	
31	5JG-14940-18	.DIAPHRAGM ASSY	1	1	1	STD
	5JG-14940-17	.DIAPHRAGM ASSY		1	1	AP
	5JG-14940-19	.DIAPHRAGM ASSY		1	1	AP
32	3TJ-14536-40	.GASKET	2	2	2	
33	5GS-14933-40	.SPRING, DIAPHRAGM	1	1	1	
34	6H4-14561-00	.O-RING	1	1	1	
35	5XC-14171-00	.PLUNGER, STARTER	1	1	1	
36	5TA-14371-00	.PLUNGER, STARTER	1	1	1	

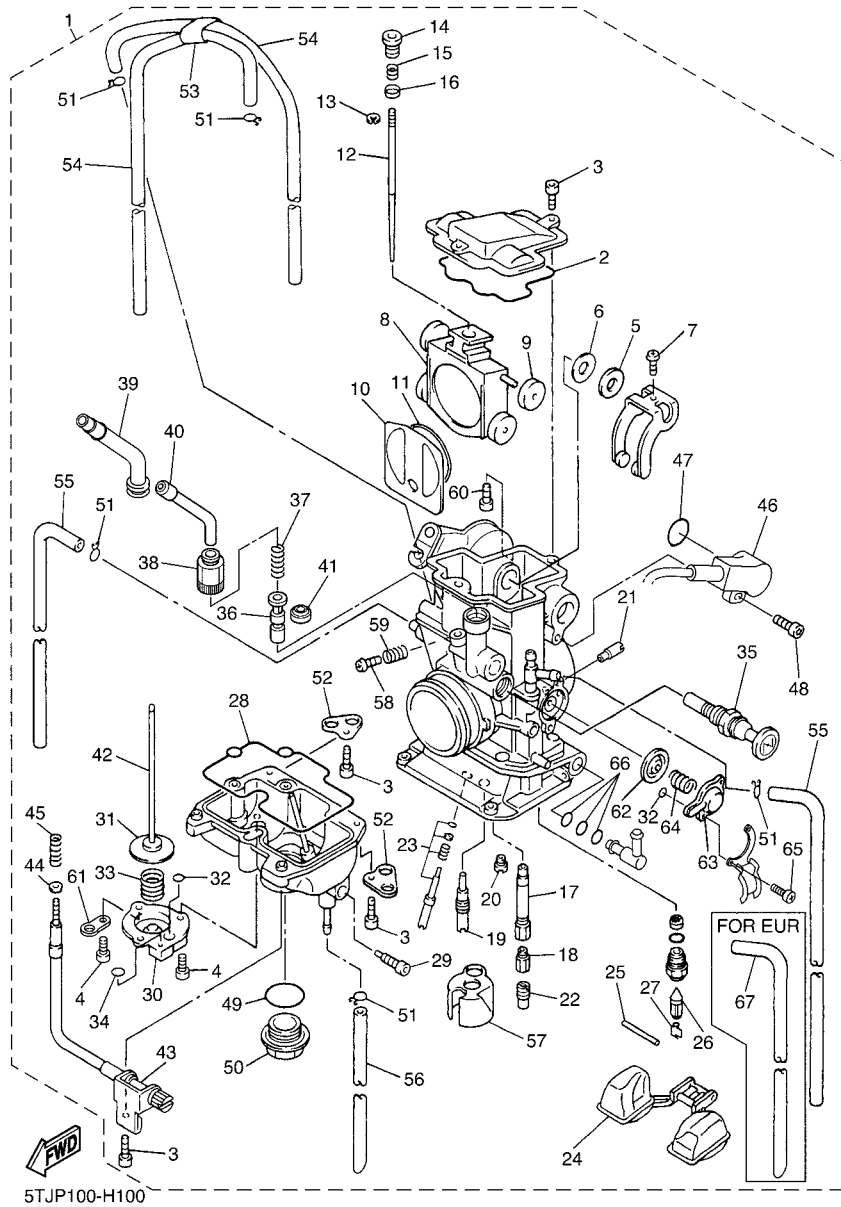

FIG. 10 CARBURETOR

REF. NO.	PART NO.	DESCRIPTION	5TJP	5TJR	5TJS	REMARKS
37	5TA-14335-00	.SPRING, PLUNGER	1	1	1	
38	5TA-14991-00	.SCREW	1	1	1	
39	2S2-14208-00	.LEVER COMP. 1	1	1	1	
40	5TA-14155-00	.GUIDE, CABLE	1	1	1	
41	5TA-14997-00	.SEAL	1	1	1	
42	5JG-14379-00	.ROD, STARTER	1	1	1	
43	5XC-14922-00	.SCREW, THROTTLE	1	1	1	
44	90201-08410	.WASHER, PLATE	1	1	1	
45	5TA-14934-00	.SPRING, THROTTLE STOP	1	1	1	
46	5XC-85885-00	.THROTTLE SENSOR ASSY	1	1	1	
47	5NX-14562-00	.O-RING	1	1	1	
48	5NX-14216-00	.SCREW	1	1	1	
49	4MX-14561-00	.O-RING	1	1	1	
50	4MX-14115-00	.PLUG, SCREW	1	1	1	
51	3TJ-14137-40	.CLIP	5	5	5	
52	5BE-14146-00	.PLATE	2	2	2	
53	5TA-14261-00	.HOLDER	1	1	1	
54	5UL-14196-00	.PIPE	2	2	2	
55	5TA-14197-00	.PIPE	2	2	2	
56	5TJ-14987-00	.HOSE	1	1	1	
57	5JG-14346-00	.PLATE	1	1	1	
58	5JG-14565-00	.SCREW	1	1	1	
59	5JG-14531-00	.SPRING, ADJUST SCREW	1	1	1	
60	5TJ-14591-10	.SCREW	1	1	1	
	5TJ-14591-20	.SCREW		1	1	
61	5PA-14146-00	.PLATE	1	1	1	

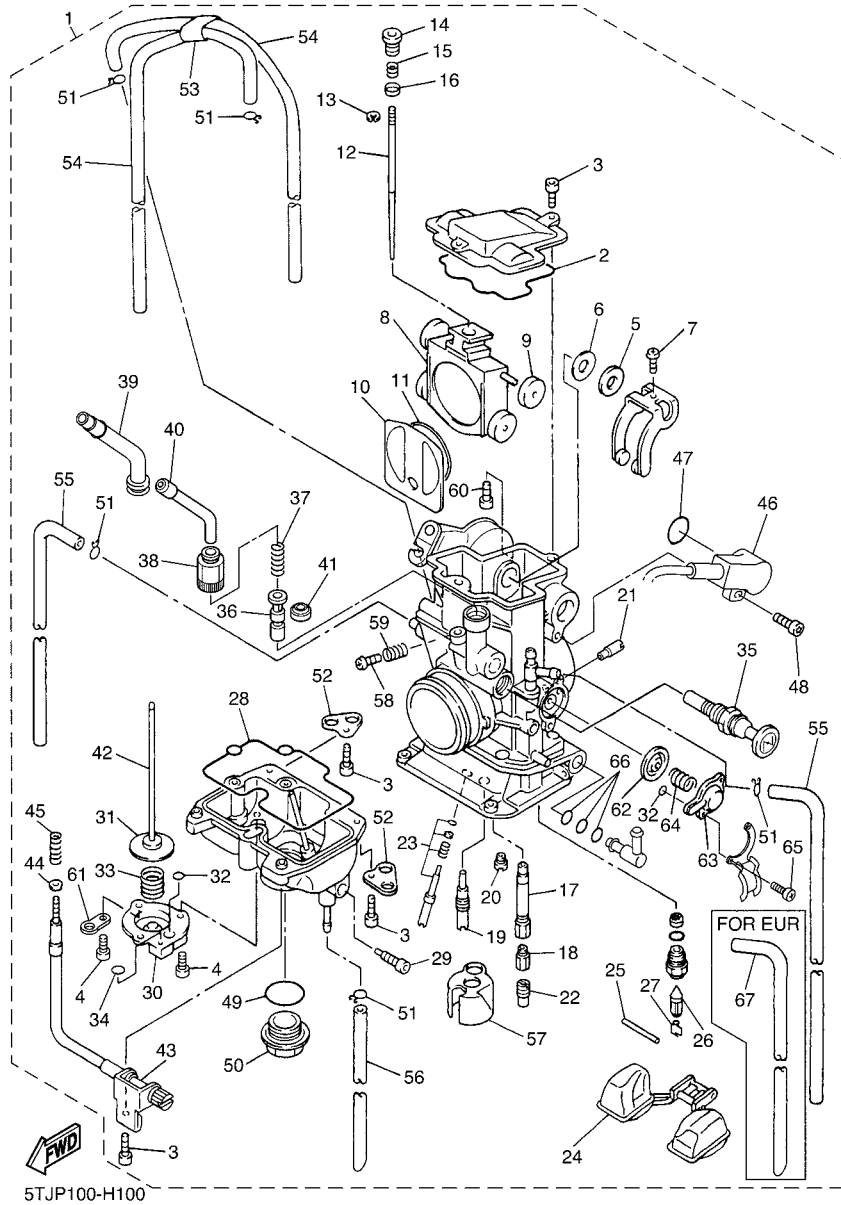
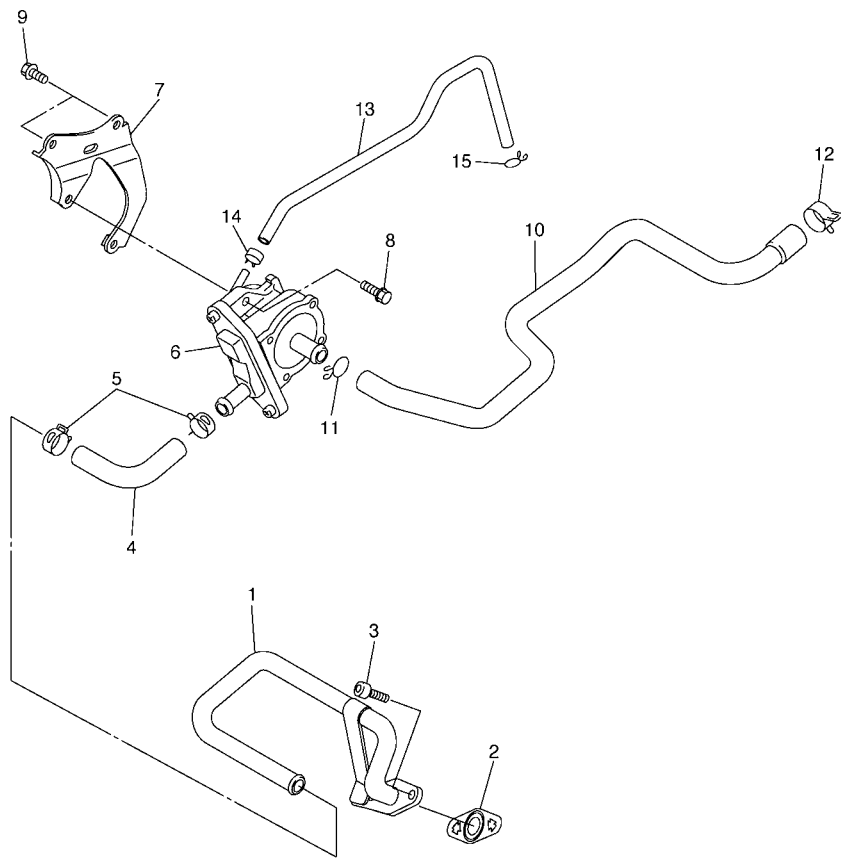

FIG. 10 CARBURETOR

REF. NO.	PART NO.	DESCRIPTION	5TJP	5TJR	5TJS	REMARKS
62	5GS-14940-00	.DIAPHRAGM ASSY	1	1	1	
63	5GS-14958-00	.COVER, DIAPHRAGM	1	1	1	
64	5GS-14933-00	.SPRING, DIAPHRAGM	1	1	1	
65	97602-04110	.SCREW, PAN HEAD WITH WASHER	2	2	2	
66	3TJ-14564-40	.O-RING	3	3	3	
67	N/A					



5TJE100-F110

FIG. 11 AIR INDUCTION SYSTEM

REF. NO.	PART NO.	DESCRIPTION	5TJP	5TJR	5TJS	REMARKS
1	5TJ-14871-10	PIPE 1	1	1	1	
2	5TJ-14815-00	GASKET	1	1	1	
3	91314-06016	BOLT, HEXAGON SOCKET HEAD	2	2	2	
4	5TJ-14881-10	HOSE, BEND 1	1	1	1	
5	90467-16063	CLIP	2	2	2	
6	5UM-14803-00	AIR INDUCTION SYSTEM ASSY	1	1	1	
7	5TJ-14834-E0	STAY	1	1	1	
8	90105-06107	BOLT, FLANGE	2	2	2	
9	90105-06105	BOLT, FLANGE	2	2	2	
10	5TJ-14882-10	HOSE, BEND 2	1	1	1	
11	90467-140A4	CLIP	1	1	1	
12	90467-17089	CLIP	1	1	1	
13	90445-082K4	HOSE (L250)	1	1	1	
14	90467-07138	CLIP	1	1	1	
15	90467-09006	CLIP	1	1	1	

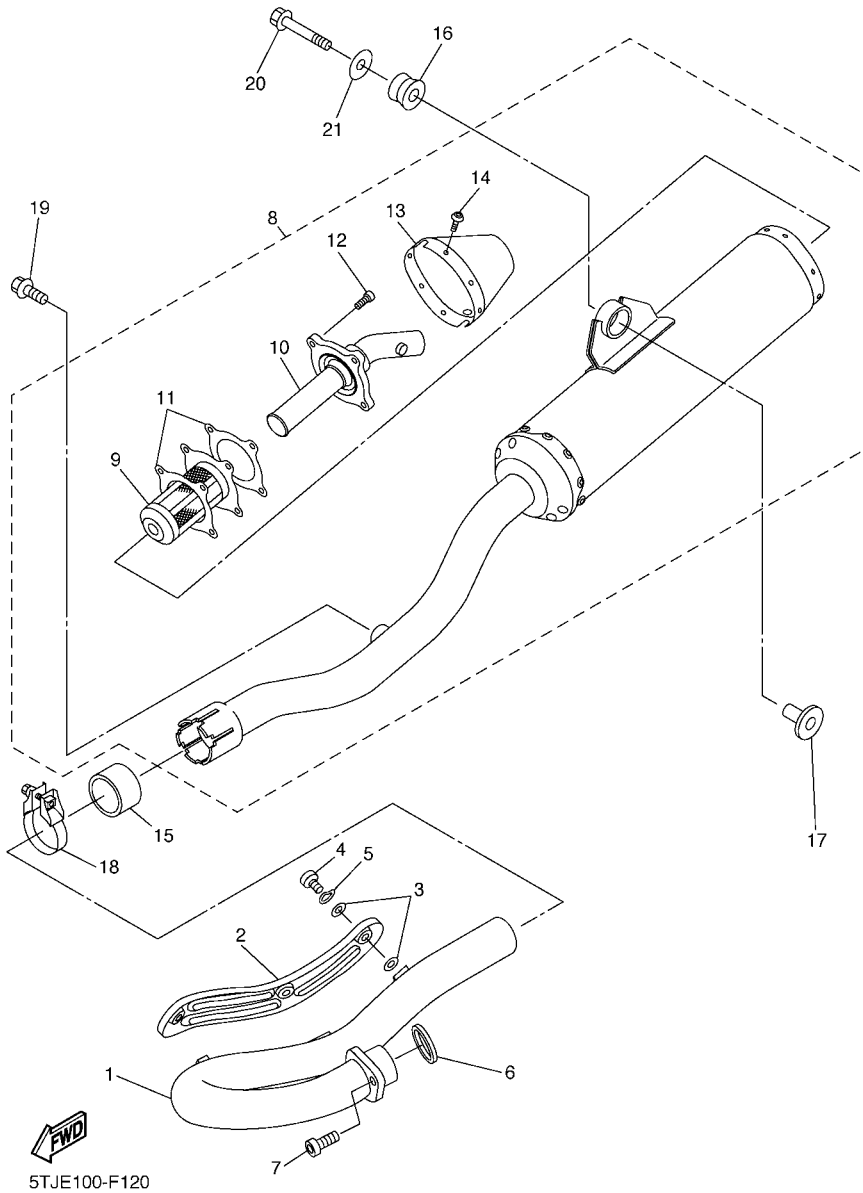
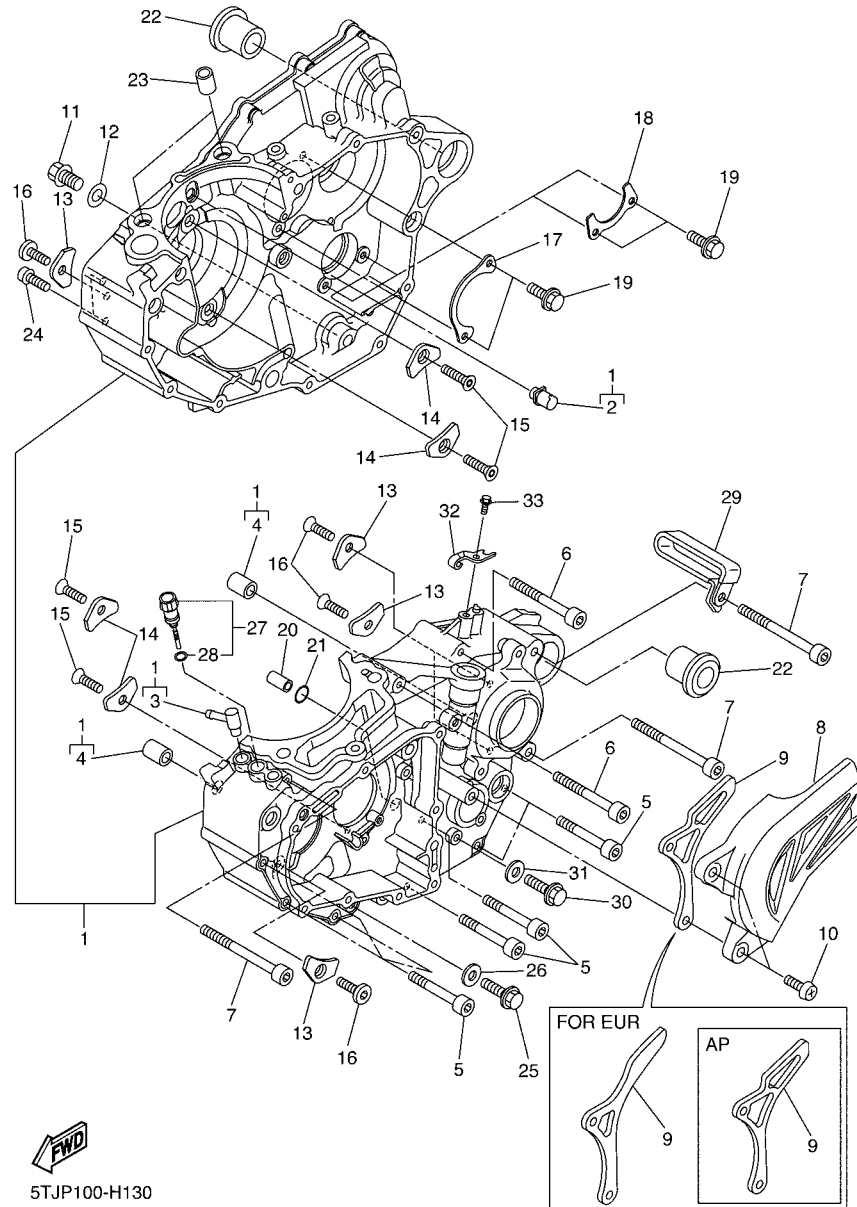

FIG. 12 EXHAUST

REF. NO.	PART NO.	DESCRIPTION	5TJF	5TJR	5TJS	REMARKS
1	5TJ-14611-10	PIPE, EXHAUST 1	1	1	1	
2	5TA-14628-00	PROTECTOR, EXHAUST PIPE	1	1	1	
3	4BD-14766-00	WASHER, PROTECTOR	6	6	6	
4	98980-06008	SCREW, BIND	3	3	3	
5	90206-06090	WASHER, WAVE	3	3	3	
6	3VD-14613-01	GASKET, EXHAUST PIPE	1	1	1	
7	90110-08097	BOLT, HEXAGON SOCKET HEAD	1	1	1	
8	5TJ-14710-E0	MUFFLER ASSY 1	1	1	1	
9	5TJ-14780-00	.SPARK ARRESTER ASSY	1	1	1	
10	5TJ-14784-00	.PIPE, TAIL	1	1	1	
11	5TJ-14623-00	.GASKET, EXHAUST PIPE	2	2	2	
12	90110-05041	.BOLT, HEXAGON SOCKET HEAD	4	4	4	
13	5TJ-14799-00	.CAP	1	1	1	
14	92012-05008	.BOLT, BUTTON HEAD	6	6	6	
15	5PH-14714-00	GASKET, MUFFLER	1	1	1	
16	5BE-14747-00	DAMPER, MUFFLER	1	1	1	
17	90387-08081	COLLAR	1	1	1	
18	5BE-14788-00	BAND, SILENCER	1	1	1	
19	90105-08307	BOLT, FLANGE	1	1	1	
20	90105-08137	BOLT, FLANGE	1	1	1	
21	90201-08061	WASHER, PLATE	1	1	1	



5TJP100-H130

FIG. 13 CRANKCASE

REF. NO.	PART NO.	DESCRIPTION	5TJP	5TJR	5TJS	REMARKS
1	2S2-15100-11	CRANKCASE ASSY	1	1	1	
2	2S2-15155-10	.NOZZLE 3	1	1	1	
3	5XC-15373-00	.PIPE, BREATHER	1	1	1	
4	99530-14016	.PIN, DOWEL	2	2	2	
5	91312-06050	BOLT	7	7	7	
6	91312-06060	BOLT	2	2	2	
7	91312-06080	BOLT	3	3	3	
8	2S2-15421-10	COVER, CRANKCASE 2	1	1	1	
9	2S2-17466-00	GUIDE, CHAIN	1	1	1	
10	98502-06025	SCREW, PAN HEAD	2	2	2	
11	95022-10016	BOLT, FLANGE	1	1	1	
12	90430-10188	GASKET	1	1	1	
13	4JT-15381-01	PLATE, BEARING COVER	4	4	4	
14	5BE-15383-01	PLATE, BEARING COVER	4	4	4	
15	90151-06071	SCREW, COUNTERSUNK	4	4	4	
16	90149-06074	SCREW	4	4	4	
17	2S2-15388-00	PLATE, BEARING COVER	1	1	1	
18	2S2-18562-00	PLATE, STOPPER 2	1	1	1	
19	90105-06081	BOLT, FLANGE	4	4	4	
20	99530-10114	PIN, DOWEL	1	1	1	
21	93210-10197	O-RING	1	1	1	
22	90387-18007	COLLAR	2	2	2	
23	99530-14016	PIN, DOWEL	2	2	2	
24	91312-06030	BOLT	2	2	2	
25	95822-08016	BOLT, FLANGE	1	1	1	

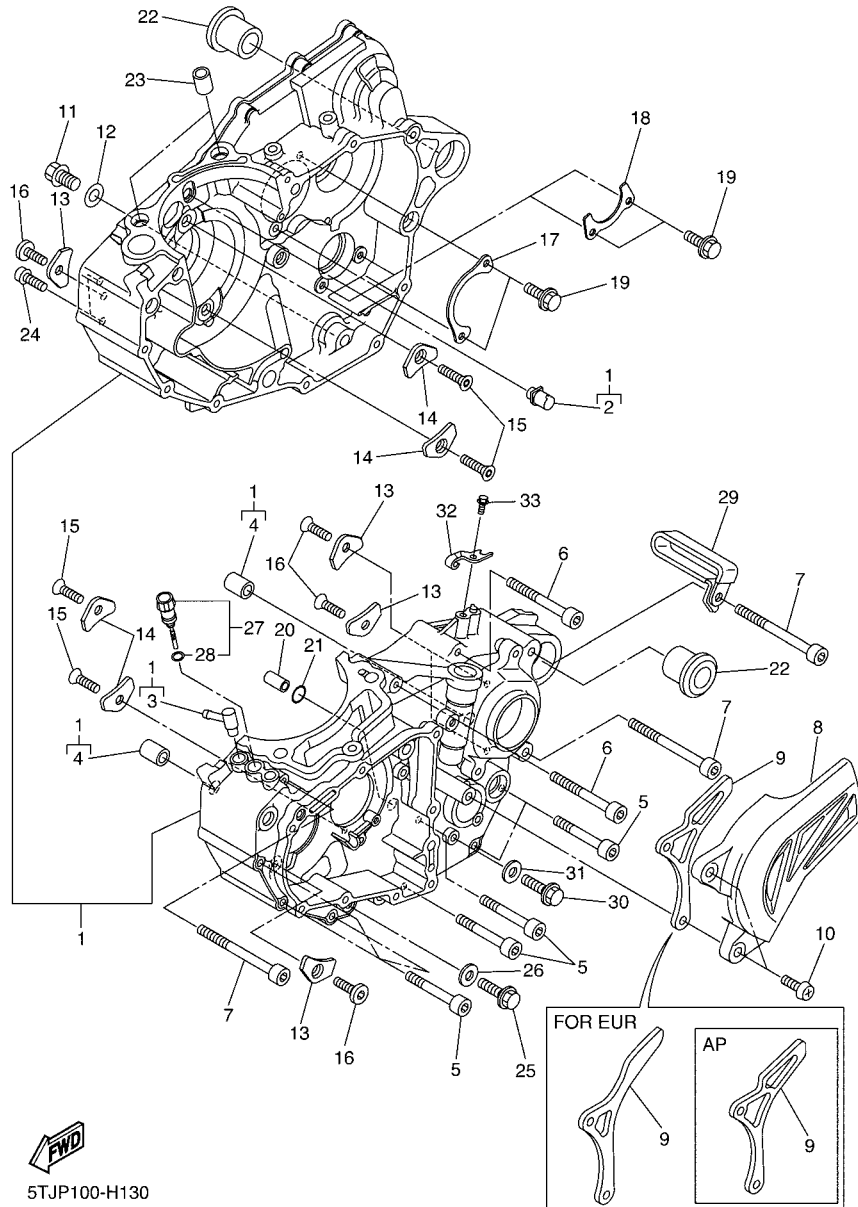

5TJP100-H130

FIG. 13 CRANKCASE

REF. NO.	PART NO.	DESCRIPTION	5TJP	5TJR	5TJS	REMARKS
26	90430-08119	GASKET	1	1	1	
27	2S2-1536A-00	PLUG, OIL LEVEL	1	1	1	
28	93210-09165	.O-RING	1	1	1	
29	90461-10136	CLAMP	1	1	1	
30	95022-06012	BOLT, FLANGE	1	1	1	
31	90430-06014	GASKET	1	1	1	
32	5TA-15441-01	HOLDER, CLUTCH CABLE	1	1	1	
33	95022-06016	BOLT, FLANGE	1	1	1	

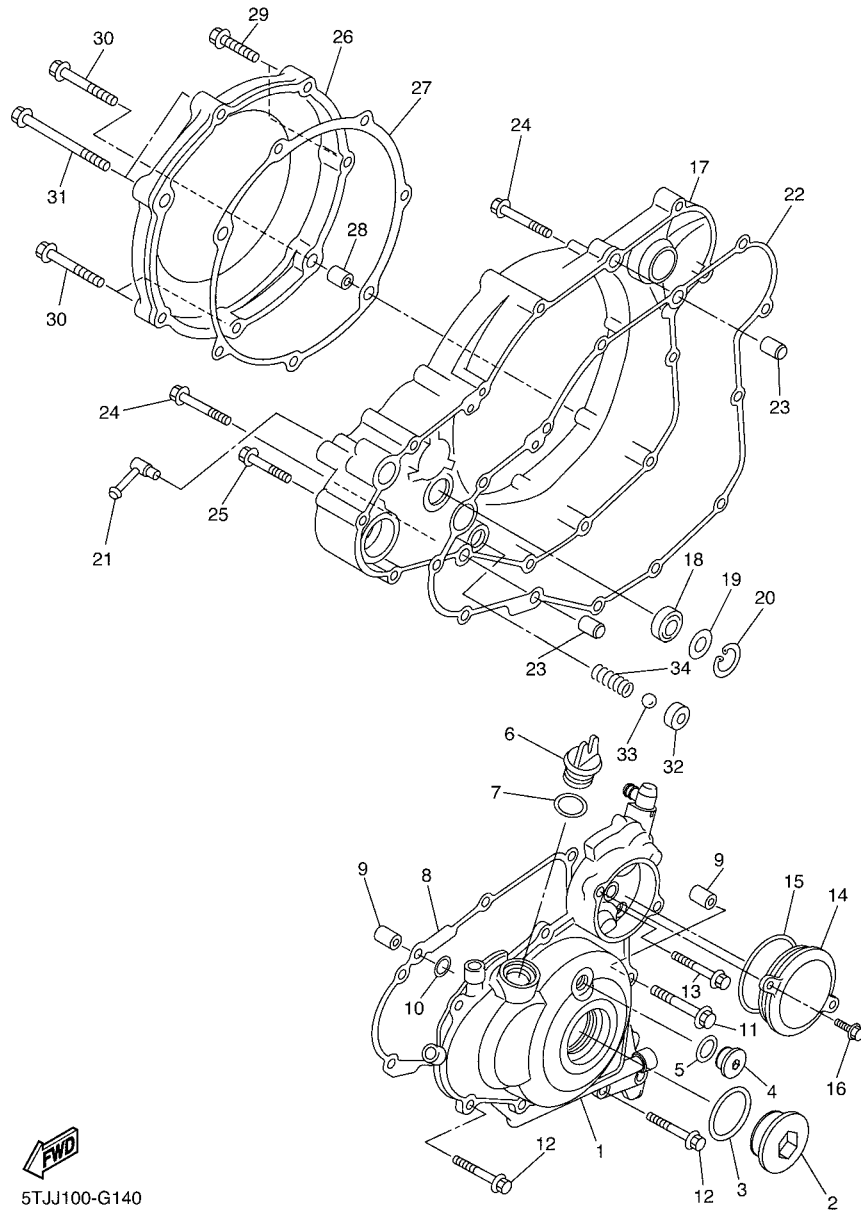

5TJJ100-G140

FIG. 14 CRANKCASE COVER 1

REF. NO.	PART NO.	DESCRIPTION	5TJP	5TJR	5TJS	REMARKS
1	5TJ-15411-30	COVER, CRANKCASE 1	1	1	1	
2	90340-27003	PLUG, STRAIGHT SCREW	1	1	1	
3	93210-27370	O-RING	1	1	1	
4	90340-14003	PLUG, STRAIGHT SCREW	1	1	1	
5	93210-14369	O-RING	1	1	1	
6	3Y1-15363-00	PLUG, OIL	1	1	1	
7	93210-19123	O-RING	1	1	1	
8	2S2-15451-00	GASKET, CRANKCASE COVER 1	1	1	1	
9	99530-08016	PIN, DOWEL	2	2	2	
10	93210-08003	O-RING	1	1	1	
11	95022-06040	BOLT, FLANGE	1	1	1	
12	95022-06030	BOLT, FLANGE	6	6	6	
13	95022-06020	BOLT, FLANGE	1	1	1	
14	5TJ-1549B-20	COVER ASSY 2	1	1	1	
15	93210-58346	O-RING	1	1	1	
16	95022-06016	BOLT, FLANGE	2	2	2	
17	2S2-15431-00	COVER, CRANKCASE 3	1	1	1	
18	93101-14164	OIL SEAL	1	1	1	
19	90201-15701	WASHER, PLATE (T=1.0)	1	1	1	
20	99009-22500	CIRCLIP	1	1	1	
21	5XC-15373-00	PIPE, BREATHER	1	1	1	
22	2S2-15462-10	GASKET, CRANKCASE COVER 3	1	1	1	
23	91812-16001	PIN, DOWEL	2	2	2	
24	95022-06040	BOLT, FLANGE	2	2	2	
25	95022-06030	BOLT, FLANGE	6	6	6	
26	5TA-15415-20	COVER, GENERATOR	1	1	1	
27	5TA-15453-00	GASKET	1	1	1	

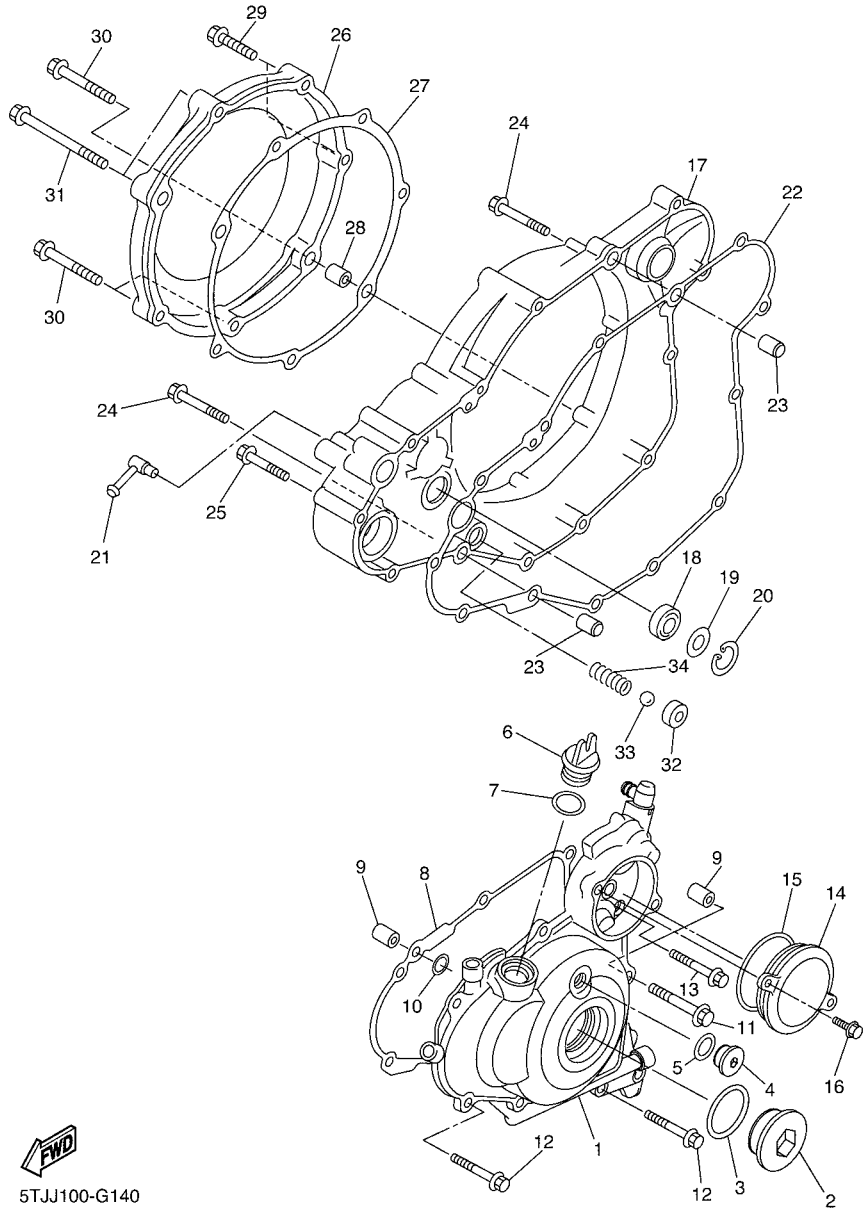

5TJJ100-G140

FIG. 14 CRANKCASE COVER 1

REF. NO.	PART NO.	DESCRIPTION	5TJF	5TJF	5TJUS	REMARKS
28	99530-08016	PIN, DOWEL	2	2	2	
29	95022-06030	BOLT, FLANGE	2	2	2	
30	95022-06040	BOLT, FLANGE	3	3	3	
31	95022-06080	BOLT, FLANGE	2	2	2	
32	583-13113-00	SEAT, CHECK BALL	1	1	1	
33	93503-08007	BALL	1	1	1	
34	90501-043E0	SPRING, COMPRESSION	1	1	1	

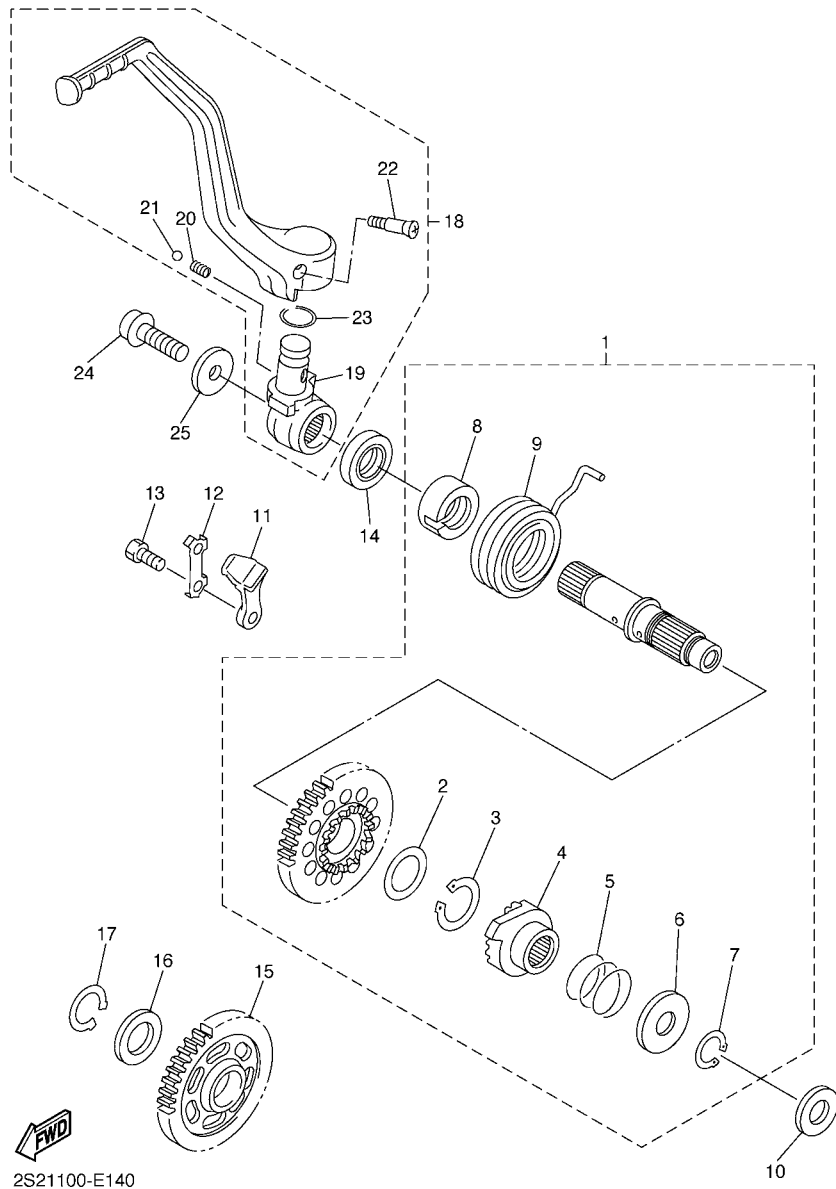
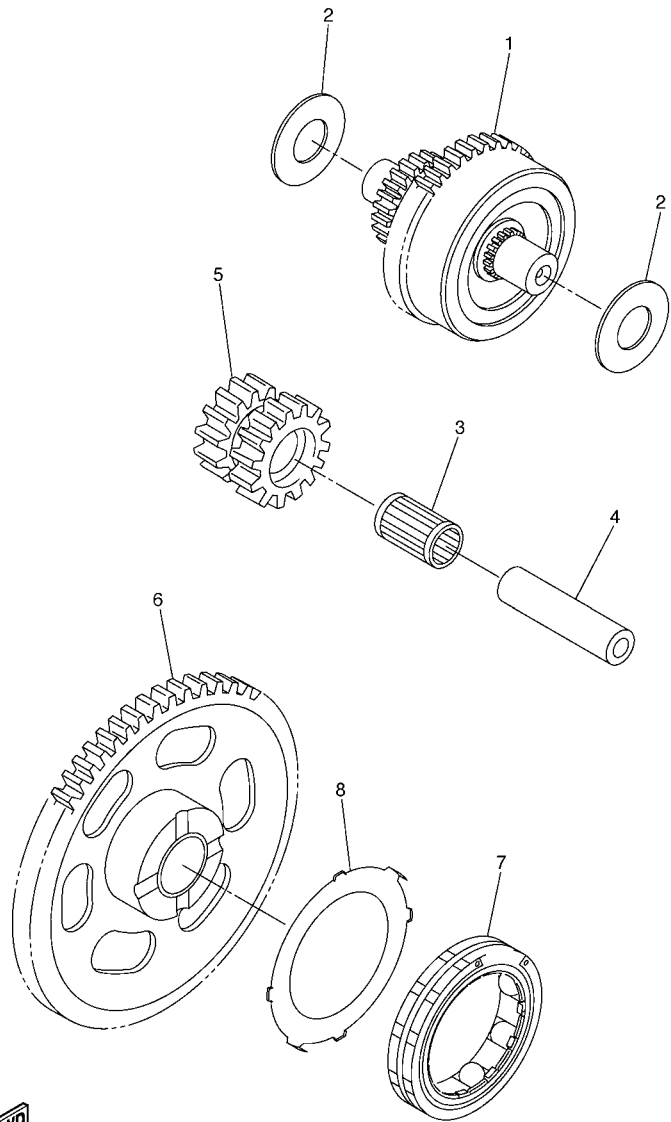

FIG. 15 STARTER

REF. NO.	PART NO.	DESCRIPTION	5TUP	5TJR	5TJS	REMARKS
1	2S2-15601-00	KICK SHAFT ASSY	1	1	1	
2	90201-20685	.WASHER, PLATE (T=0.5)	1	1	1	
3	93410-20038	.CIRCLIP	1	1	1	
4	2S2-15671-00	.WHEEL, RATCHET	1	1	1	
5	90501-160A2	.SPRING, COMPRESSION	1	1	1	
6	90201-167P7	.WASHER, PLATE	1	1	1	
7	99009-16400	.CIRCLIP	1	1	1	
8	5GR-15664-00	.GUIDE, SPRING	1	1	1	
9	90508-305B0	.SPRING, TORSION	1	1	1	
10	90201-162H4	WASHER, PLATE	1	1	1	
11	5SG-15668-00	STOPPER	1	1	1	
12	214-15686-00	WASHER, LOCK	1	1	1	
13	90101-06044	BOLT	2	2	2	
14	93102-20108	OIL SEAL	1	1	1	
15	5TA-15651-00	GEAR, KICK IDLE	1	1	1	
16	90201-20685	WASHER, PLATE (T=0.5)	1	1	1	
17	99009-20400	CIRCLIP	1	1	1	
18	2S2-15620-01	KICK CRANK ASSY	1	1	1	
19	5XD-15621-00	.BOSS, KICK CRANK	1	1	1	
20	90501-147A5	.SPRING, COMPRESSION	1	1	1	
21	93507-32009	.BALL	1	1	1	
22	90152-06010	.SCREW, COUNTERSUNK	1	1	1	
23	93210-17570	.O-RING	1	1	1	
24	90110-08087	BOLT, HEXAGON SOCKET HEAD	1	1	1	
25	90201-08047	WASHER, PLATE	1	1	1	



5TJE100-F160

FIG. 16 STARTER CLUTCH

REF. NO.	PART NO.	DESCRIPTION	5TJUP	5TJUR	5TJUS			REMARKS
1	5TJ-15560-20	DAMPER ASSY	1	1	1			
2	90201-105A8	WASHER, PLATE	2	2	2			
3	93310-212R6	BEARING	1	1	1			
4	4GY-15521-00	SHAFT 1	1	1	1			
5	5TJ-15517-00	GEAR, IDLER 2	1	1	1			
6	5TG-15515-01	GEAR 3	1	1	1			
7	5UM-15570-00	STARTER CLUTCH ASSY	1	1	1			
8	5VY-15586-00	PLATE, STARTER CLUTCH ASSY	1	1	1			
<hr/>								
<hr/>								
<hr/>								
<hr/>								
<hr/>								
<hr/>								
<hr/>								
<hr/>								
<hr/>								

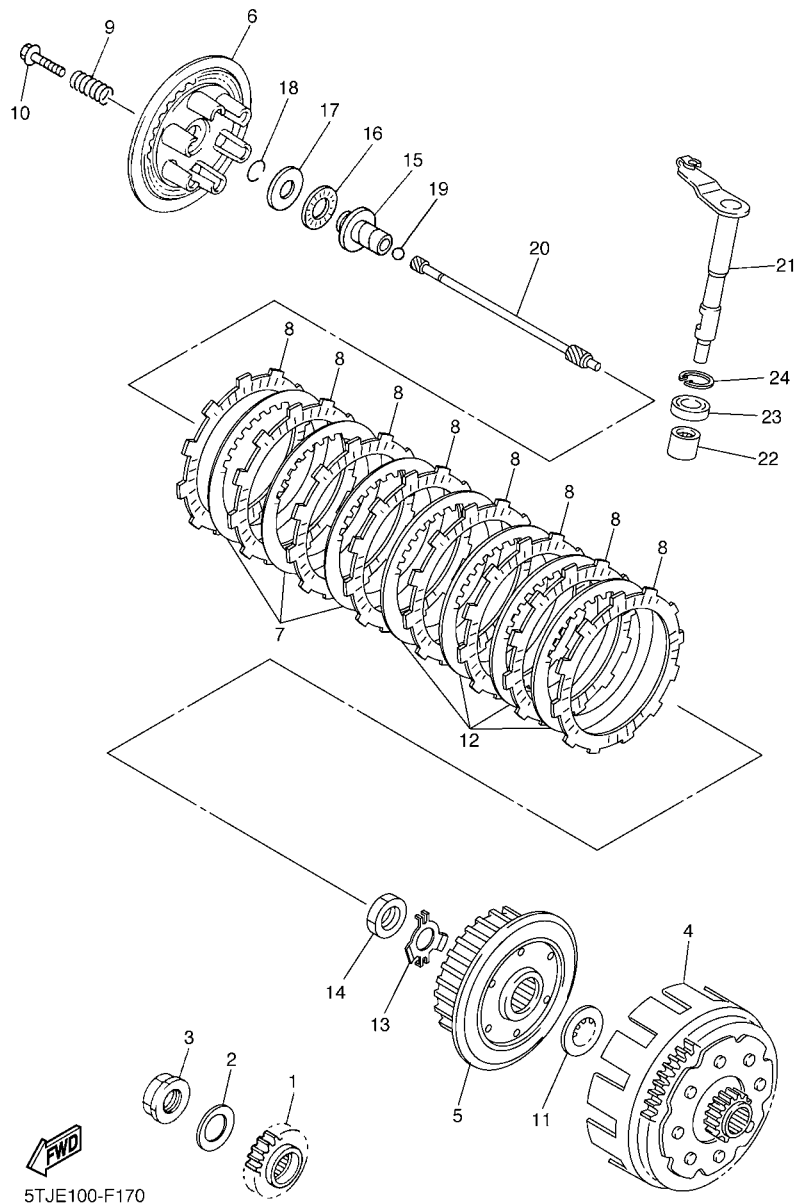

5TJE100-F170

FIG. 17 CLUTCH

REF. NO.	PART NO.	DESCRIPTION	5TJP	5TJR	5TJS	REMARKS
1	2S2-16111-60	GEAR, PRIMARY DRIVE	1	1	1	
2	90208-25045	WASHER, CONICAL SPRING	1	1	1	
3	90179-20009	NUT	1	1	1	
4	5XD-16150-60	PRIMARY DRIVEN GEAR COMP.	1	1	1	
5	5TA-16371-10	BOSS, CLUTCH	1	1	1	
6	5JG-16351-00	PLATE, PRESSURE 1	1	1	1	
7	4X7-16325-00	PLATE, CLUTCH 2	3	3	3	
8	5TA-16321-00	PLATE, FRICTION	8	8	8	
9	90501-237L0	SPRING, COMPRESSION	6	6	6	
10	90159-06092	SCREW, WITH WASHER	6	6	6	
11	5XD-16154-00	PLATE, THRUST 1	1	1	1	
12	1TA-16325-00	PLATE, CLUTCH 2	4	4	4	
13	90215-20005	WASHER, LOCK	1	1	1	
14	90170-20327	NUT	1	1	1	
15	5JG-16356-00	ROD, PUSH 1	1	1	1	
16	93340-21505	BEARING	1	1	1	
17	90201-125L6	WASHER, PLATE	1	1	1	
18	93440-10085	CIRCLIP	1	1	1	
19	93511-32027	BALL	1	1	1	
20	2S2-16357-00	ROD, PUSH 2	1	1	1	
21	5TJ-16381-20	PUSH LEVER COMP.	1	1	1	
22	93317-11287	BEARING	1	1	1	
23	93102-12224	OIL SEAL	1	1	1	
24	99009-20500	CIRCLIP	1	1	1	

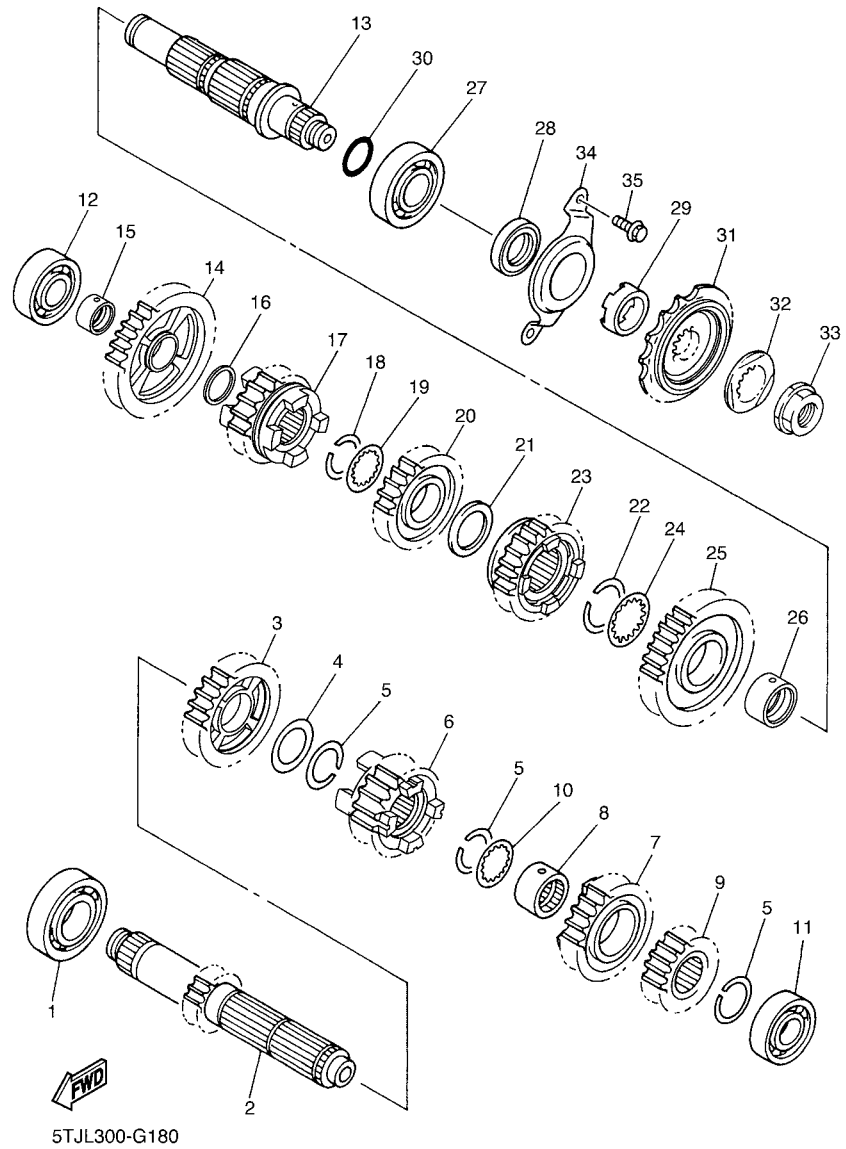
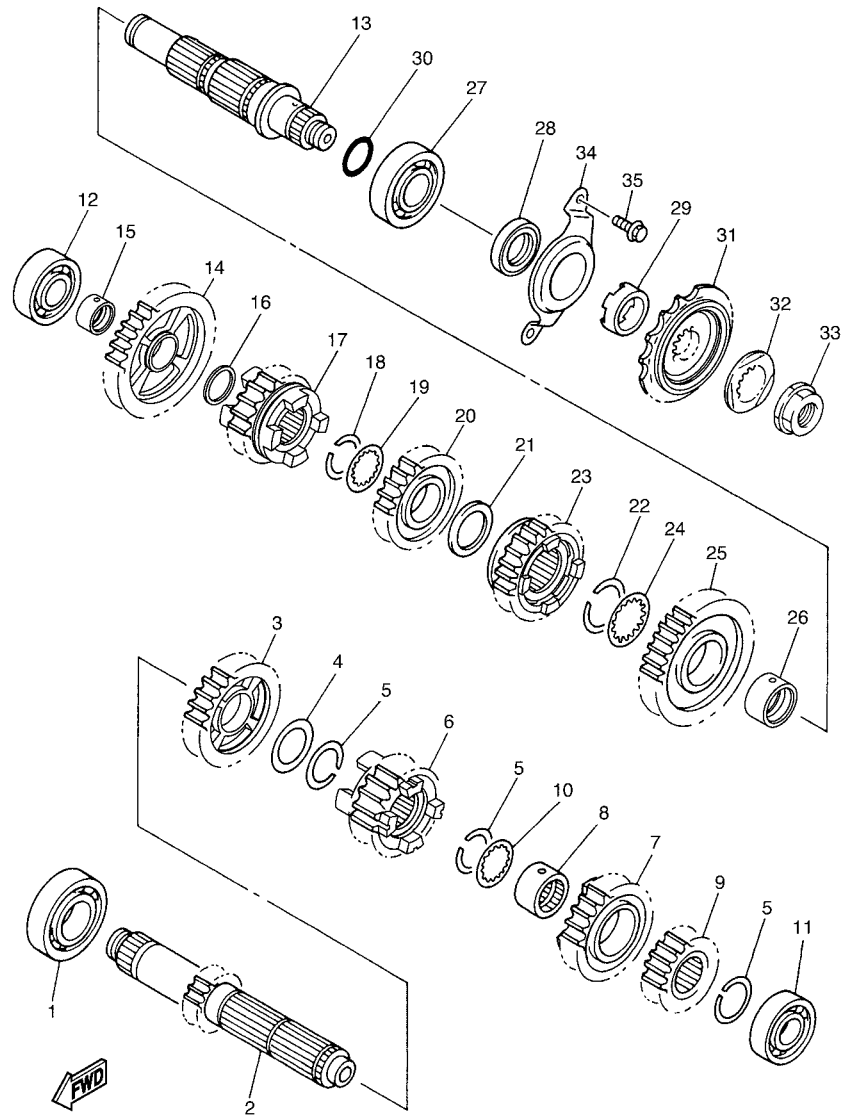

FIG. 18 TRANSMISSION

REF. NO.	PART NO.	DESCRIPTION	5TJF	5TJR	5TJS	REMARKS
1	93306-20532	BEARING	1	1	1	
2	5TJ-17411-20	AXLE,MAIN(12T)	1	1	1	
3	5TJ-17151-20	GEAR, 5TH PINION(25T)	1	1	1	
4	90201-253K0	WASHER, PLATE (T=1.0)	1	1	1	
5	93440-25084	CIRCLIP	3	3	3	
6	5TJ-17131-20	GEAR, 3RD PINION(16T)	1	1	1	
7	5TJ-17141-20	GEAR, 4TH PINION (20T)	1	1	1	
8	90387-21005	COLLAR	1	1	1	
9	5TJ-17121-20	GEAR, 2ND PINION(15T)	1	1	1	
10	90209-21332	WASHER	1	1	1	
11	93306-00431	BEARING	1	1	1	
12	93306-00426	BEARING	1	1	1	
13	2S2-17402-00	DRIVE AXLE ASSY	1	1	1	
14	5TJ-17211-20	GEAR, 1ST WHEEL(29T)	1	1	1	
15	90387-20028	COLLAR	1	1	1	
16	90201-203E7	WASHER, PLATE	1	1	1	
17	5TJ-17251-20	GEAR, 5TH WHEEL(21T)	1	1	1	
18	93440-25084	CIRCLIP	1	1	1	
19	90209-21332	WASHER	1	1	1	
20	5TJ-17231-20	GEAR, 3RD WHEEL(21T)	1	1	1	
21	90201-253K0	WASHER, PLATE (T=1.0)	1	1	1	
22	93440-28062	CIRCLIP	1	1	1	
23	5TJ-17241-20	GEAR, 4TH WHEEL(21T)	1	1	1	
24	90209-26348	WASHER	1	1	1	
25	5TJ-17221-20	GEAR, 2ND WHEEL(26T)	1	1	1	
26	90387-28012	COLLAR	1	1	1	
27	93306-205A5	BEARING	1	1	1	



5TJL300-G180

FIG. 18 TRANSMISSION

REF. NO.	PART NO.	DESCRIPTION	5TJUP	5TJUF	5TJUS	REMARKS
28	93102-32480	OIL SEAL	1	1	1	
29	90387-2513F	COLLAR	1	1	1	
30	93210-22164	O-RING	1	1	1	
31	9383E-13233	SPROCKET DRIVE(13T)			1	
	9383E-14215	SPROCKET, DRIVE (14T)			1	AP
32	90215-21003	WASHER, LOCK	1	1	1	
33	90179-20001	NUT	1	1	1	
34	2S2-17471-00	PLATE, COVER	1	1	1	
35	90105-06081	BOLT, FLANGE	2	2	2	

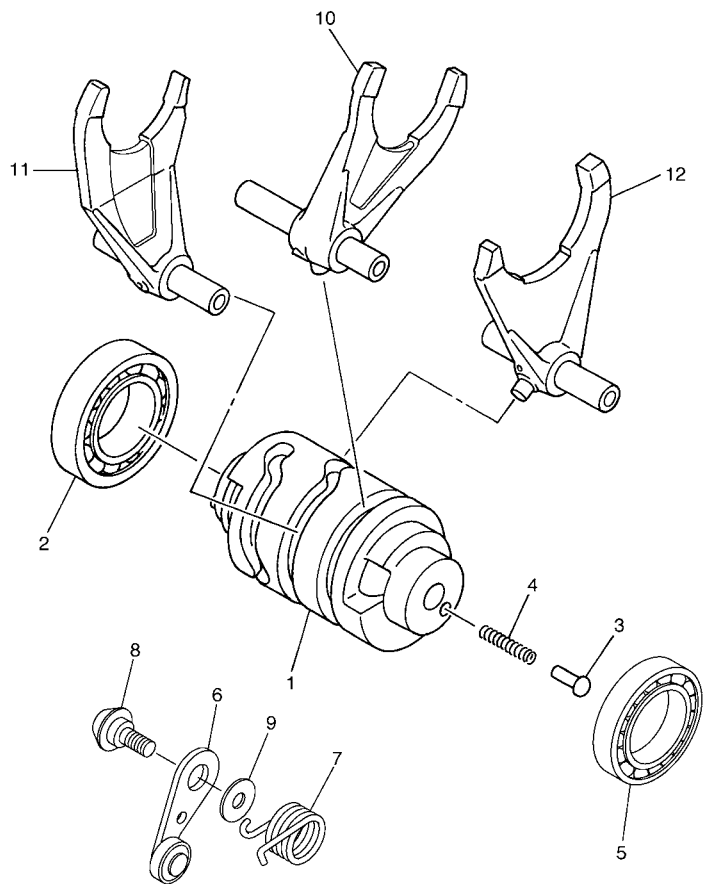

2S27100-F170

FIG. 19 SHIFT CAM & FORK

REF. NO.	PART NO.	DESCRIPTION	5TUP	5TJR	5TJS	REMARKS
1	5NL-18541-00	CAM, SHIFT	1	1	1	
2	93306-90509	BEARING	1	1	1	
3	278-18542-00	POINT, NEUTRAL	1	1	1	
4	90501-06022	SPRING, COMPRESSION	1	1	1	
5	93306-80501	BEARING	1	1	1	
6	2S2-18140-10	STOPPER LEVER ASSY	1	1	1	
7	90508-26021	SPRING, TORSION	1	1	1	
8	90109-06198	BOLT	1	1	1	
9	90201-06013	WASHER, PLATE	1	1	1	
10	34P-18501-00	FORK, SHIFT 1	1	1	1	
11	2S2-18502-00	FORK, SHIFT 2	1	1	1	
12	34P-18503-00	FORK, SHIFT 3	1	1	1	

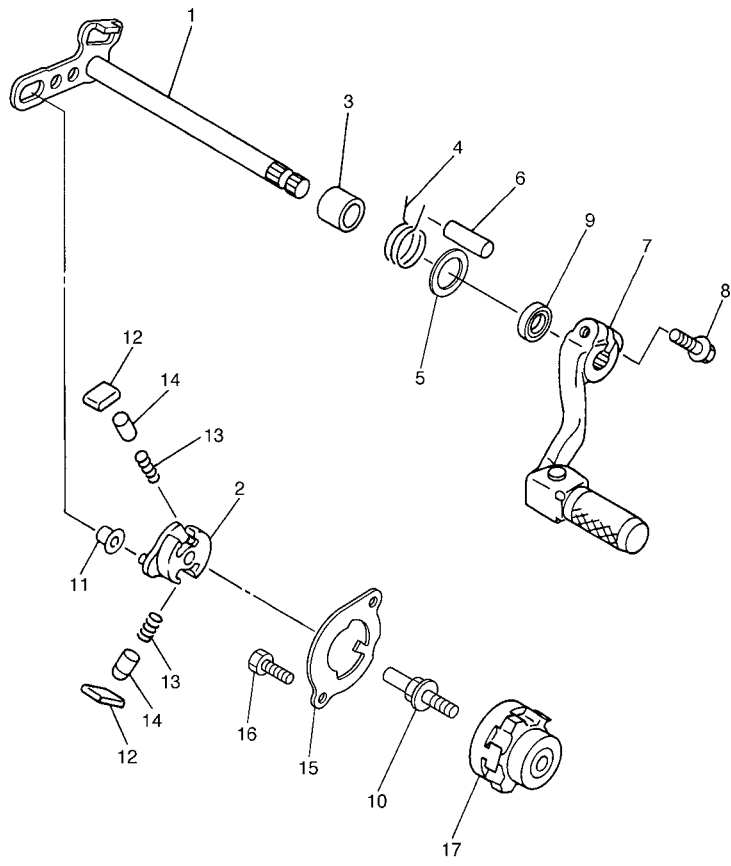
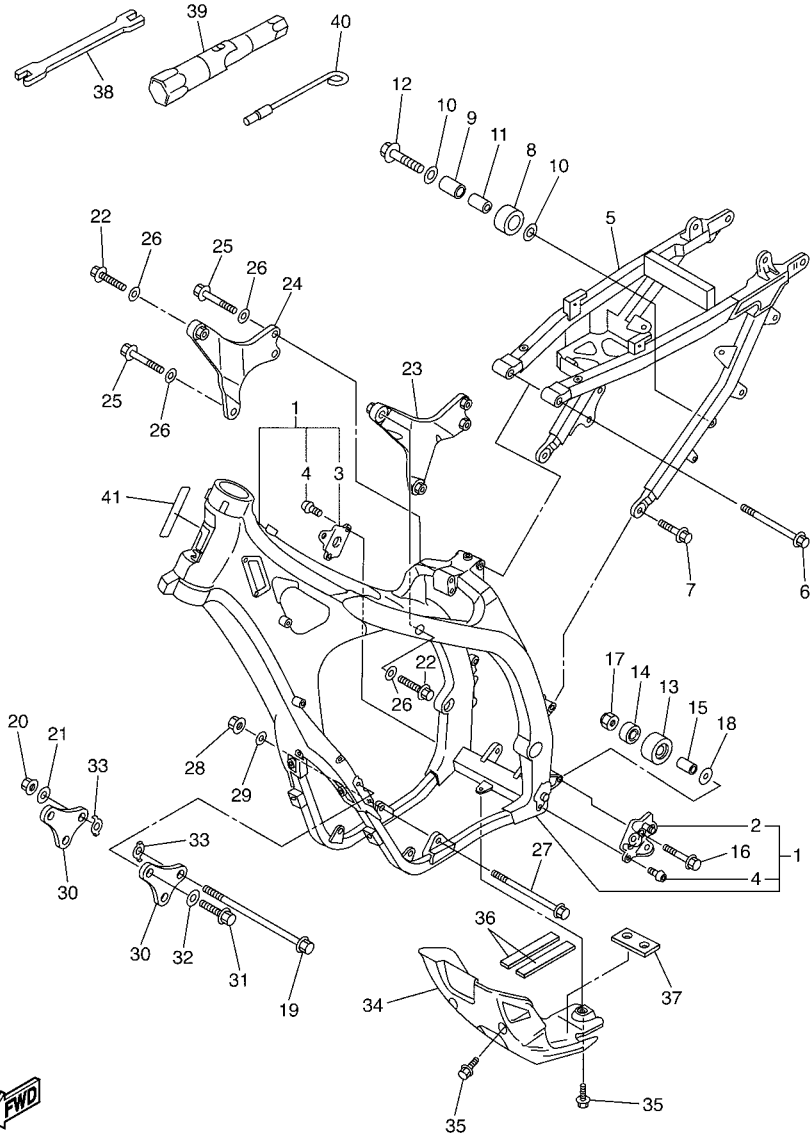

FIG. 20 SHIFT SHAFT

REF. NO.	PART NO.	DESCRIPTION	5TUP	5TJR	5TJS	REMARKS
1	2S2-18101-00	SHIFT SHAFT ASSY	1	1	1	
2	5MW-18122-01	LEVER, SHIFT 2	1	1	1	
3	90387-124F4	COLLAR	1	1	1	
4	90508-29021	SPRING, TORSION	1	1	1	
5	90201-127E1	WASHER, PLATE	1	1	1	
6	93608-33002	PIN, DOWEL	1	1	1	
7	5XC-18110-00	SHIFT PEDAL ASSY	1	1	1	
8	95022-06020	BOLT, FLANGE	1	1	1	
9	93102-12224	OIL SEAL	1	1	1	
10	3XJ-18173-10	PIN, SHIFT	1	1	1	
11	3XJ-18178-00	ROLLER, SHIFT LEVER	1	1	1	
12	3XJ-18182-00	PAWL, SHIFTER	2	2	2	
13	90501-052G5	SPRING, COMPRESSION	2	2	2	
14	3XJ-18184-00	PIN, PAWL	2	2	2	
15	5TJ-18172-00	GUIDE, SHIFT	1	1	1	
16	90101-06041	BOLT	2	2	2	
17	2S2-18185-00	SEGMENT	1	1	1	



2S21100-E180



5TJP100-H210

FIG. 21 FRAME

REF. NO.	PART NO.	DESCRIPTION	5TJP	5TJR	5TJS	REMARKS
1	5TJ-21101-E0	FRONT FRAME COMP.	1	1	1	
2	5UM-21447-E0	.BRACKET, FOOTREST	1	1	1	
3	1C3-21448-10	.BRACKET, FOOTREST	1	1	1	
4	90149-10031	.SCREW	4	4	4	
5	5UM-21190-E0	REAR FRAME COMP.	1	1	1	
6	90105-08156	BOLT, FLANGE	1	1	1	
7	90105-08307	BOLT, FLANGE	2	2	2	
8	30X-22178-00	TENSIONER	1	1	1	
9	4V4-22184-00	BUSH	1	1	1	
10	90201-08045	WASHER, PLATE	2	2	2	
11	90387-08041	COLLAR	1	1	1	
12	95022-08040	BOLT, FLANGE	1	1	1	
13	3JD-22178-20	TENSIONER	1	1	1	
14	93300-60839	BEARING	1	1	1	
15	90387-086N4	COLLAR	1	1	1	
16	90105-08133	BOLT, FLANGE	1	1	1	
17	90185-08009	NUT, SELF-LOCKING	1	1	1	
18	90201-08043	WASHER, PLATE	1	1	1	
19	90105-10193	BOLT, FLANGE	1	1	1	
20	90179-10658	NUT	1	1	1	
21	90201-10045	WASHER, PLATE	1	1	1	
22	90105-10189	BOLT, FLANGE	2	2	2	
23	2S2-21425-70	BRACKET, REAR UPPER 1	1	1	1	
24	2S2-21426-70	BRACKET, REAR UPPER 2	1	1	1	
25	90105-10191	BOLT, FLANGE	3	3	3	
26	90201-10045	WASHER, PLATE	5	5	5	
27	90105-10176	BOLT, FLANGE	1	1	1	

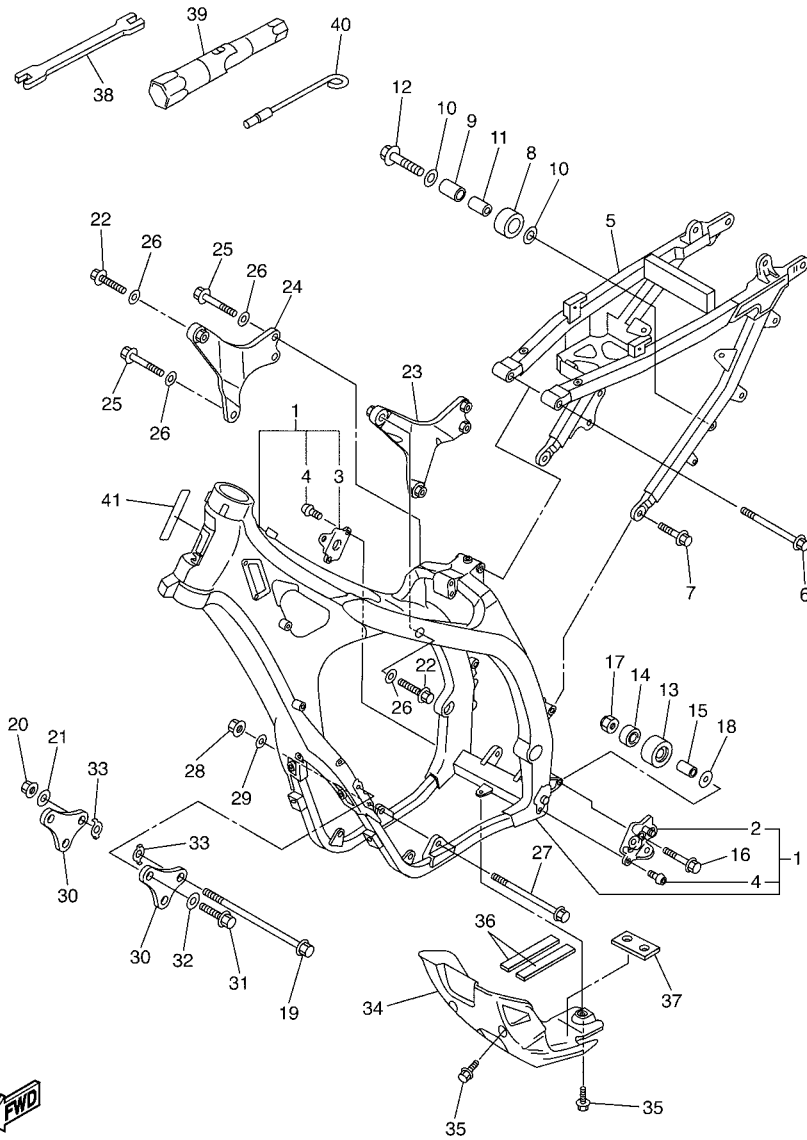

5TJP100-H210

FIG. 21 FRAME

REF. NO.	PART NO.	DESCRIPTION	5TJP	5TJR	5TJS	REMARKS
			1	1	1	
28	90179-10658	NUT	1	1	1	
29	90201-10045	WASHER, PLATE	1	1	1	
30	2S2-21417-00	BRACKET, FRONT LOWER 1	2	2	2	
31	90105-08143	BOLT, FLANGE	4	4	4	
32	92902-08200	WASHER	4	4	4	
33	5XC-21456-90	PLATE, PATCH	2	2	2	
34	5UM-2147A-E0	GUARD, ENGINE 1	1	1	1	
35	90119-06166	BOLT, WITH WASHER	3	3	3	
36	5UM-21486-E0	DAMPER 2	2	2	2	
37	5TJ-21485-E0	DAMPER, RUBBER 1	1	1	1	
38	5ET-28166-10	WRENCH, HEXAGON	1	1	1	
39	5TA-2814F-00	BOX, SPARK PLUG	1	1	1	
40	5XC-28116-00	TOOL, SPECIAL		1	1	
41	5UM-21268-E0	SEAL	1	1	1	

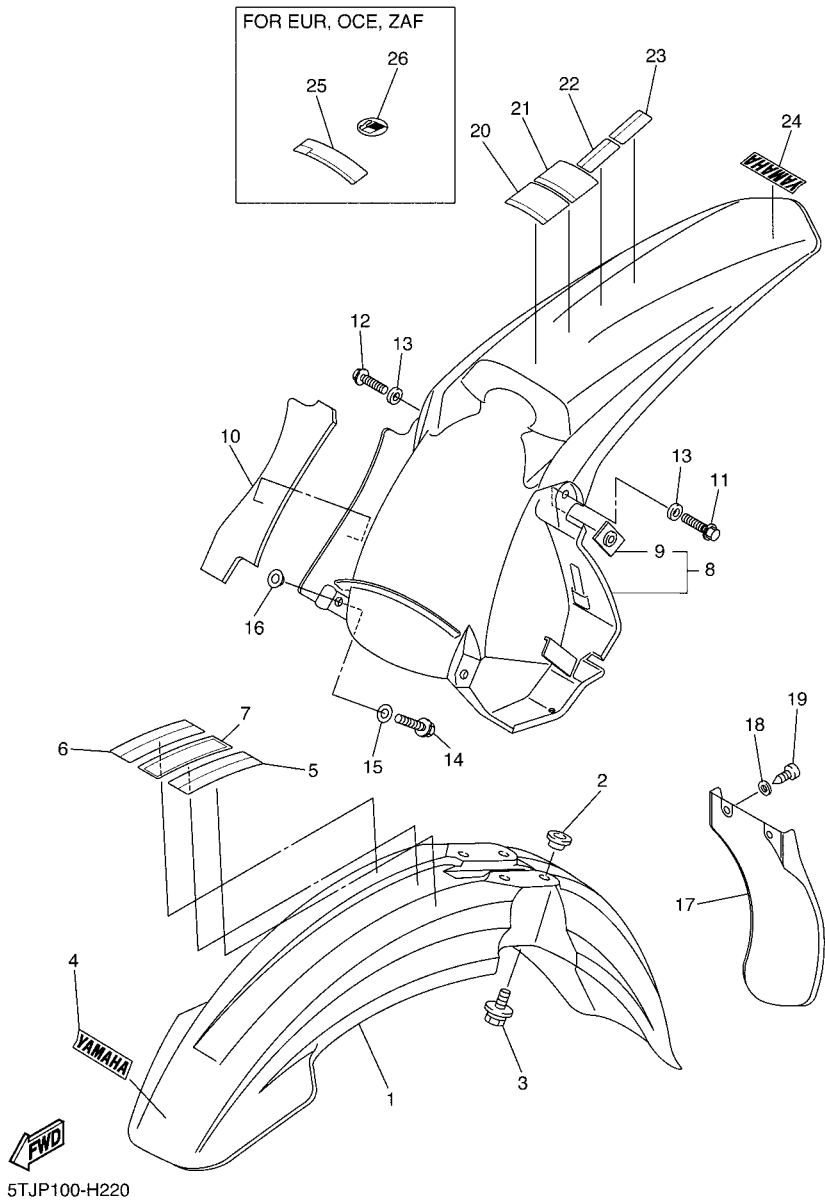
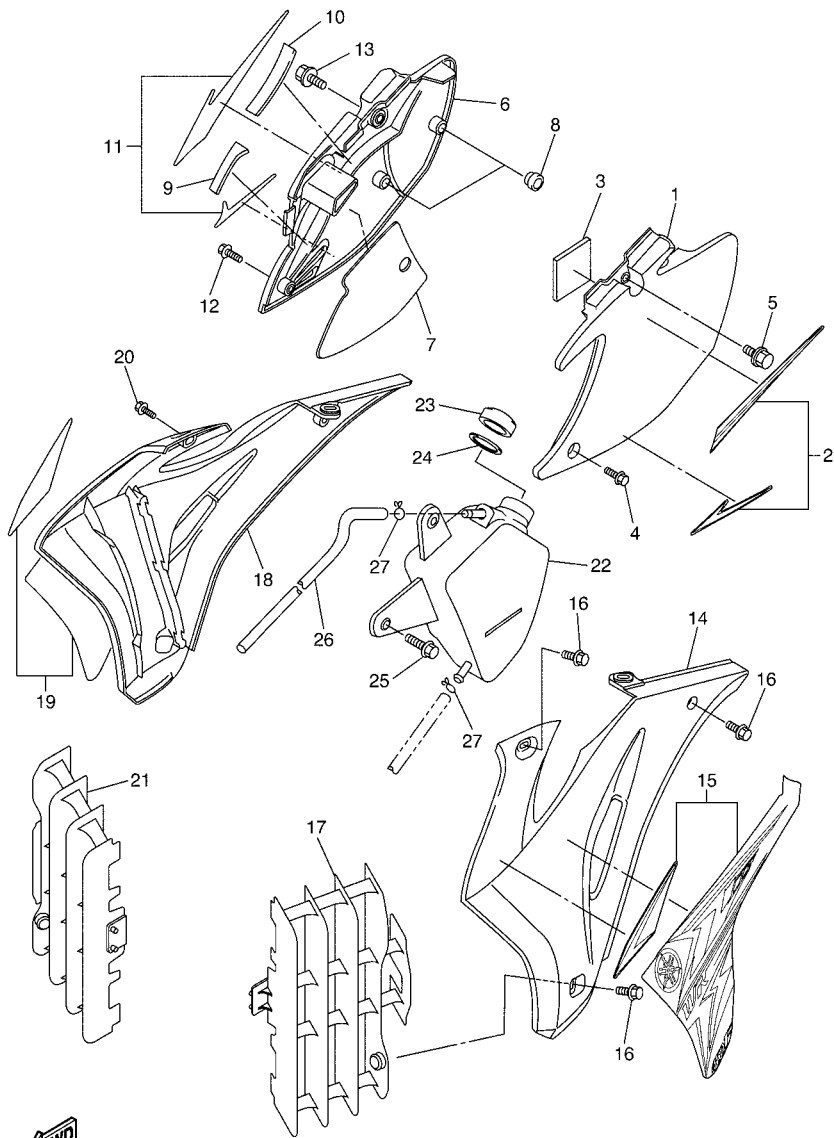

FIG. 22 FENDER

REF. NO.	PART NO.	DESCRIPTION	5TJP	5TJR	5TJS	REMARKS
1	1C3-21511-51	FENDER, FRONT	1	1	1	
2	90387-06090	COLLAR	4	4	4	
3	90119-06147	BOLT, WITH WASHER	4	4	4	
4	4ES-2153E-01	EMBLEM, YAMAHA	1	1	1	
8	5UM-21610-E0	REAR FENDER COMP.	1	1	1	
9	5XE-21635-10	.NUT, REAR FENDER	2	2	2	
10	5UM-2174T-E0	INSULATOR, SIDE COVER 2	1	1	1	
11	90105-06127	BOLT, FLANGE	1	1	1	
12	90105-06100	BOLT, FLANGE	1	1	1	
13	90201-06032	WASHER, PLATE	2	2	2	
14	90105-06106	BOLT, FLANGE	2	2	2	
15	90201-06571	WASHER, PLATE	2	2	2	
16	90387-06009	COLLAR	2	2	2	
17	5TA-21642-00	GUARD, FLAP	1	1	1	
18	90201-06084	WASHER, PLATE	2	2	2	
19	97702-60016	SCREW, TAPPING	2	2	2	
24	5UM-2153E-00	EMBLEM, YAMAHA	1	1	1	
25	5PA-21568-01	LABEL, WARNING		1	1	



5TJP100-H230

FIG. 23 SIDE COVER

REF. NO.	PART NO.	DESCRIPTION	5TJP	5TJR	5TJS	REMARKS
1	5UM-21711-E0	COVER, SIDE 1	1	1	1	
2	5TJ-2167A-10	GRAPHIC SET	1	1	1	
3	5UM-21717-E0	DAMPER	1	1	1	
4	90105-06103	BOLT, FLANGE	1	1	1	
5	90119-08095	BOLT, WITH WASHER	1	1	1	
6	5UM-21721-E0	COVER, SIDE 2	1	1	1	
7	5UM-2174A-E0	INSULATOR, SIDE COVER	1	1	1	
8	5XC-21719-90	GROMMET	2	2	2	
9	5UM-2172S-E0	INSULATOR 3	1	1	1	
10	5UM-2173S-E0	INSULATOR 4	1	1	1	
11	5TJ-2167B-10	GRAPHIC SET 2	1	1	1	
12	90105-06103	BOLT, FLANGE	1	1	1	
13	90119-08095	BOLT, WITH WASHER	1	1	1	
14	5UM-21730-E0	SIDE COVER ASSY 3	1	1	1	
15	5TJ-2173L-10	GRAPHIC SET 1	1	1	1	
16	90105-06064	BOLT, FLANGE	4	4	4	
17	5TJ-2172A-E0	PANEL 1	1	1	1	
18	5UM-21740-E0	SIDE COVER ASSY 4	1	1	1	
19	5TJ-2174L-10	GRAPHIC SET 2	1	1	1	
20	90105-06064	BOLT, FLANGE	4	4	4	
21	2S2-2172A-80	PANEL 1	1	1	1	
22	5UM-21860-E0	TANK ASSY	1	1	1	
23	26H-21875-00	CAP	1	1	1	
24	26H-21874-00	GASKET	1	1	1	
25	90119-06146	BOLT, WITH WASHER	1	1	1	
26	5UM-1244J-E0	HOSE 6	1	1	1	
27	90467-090A2	CLIP	2	2	2	

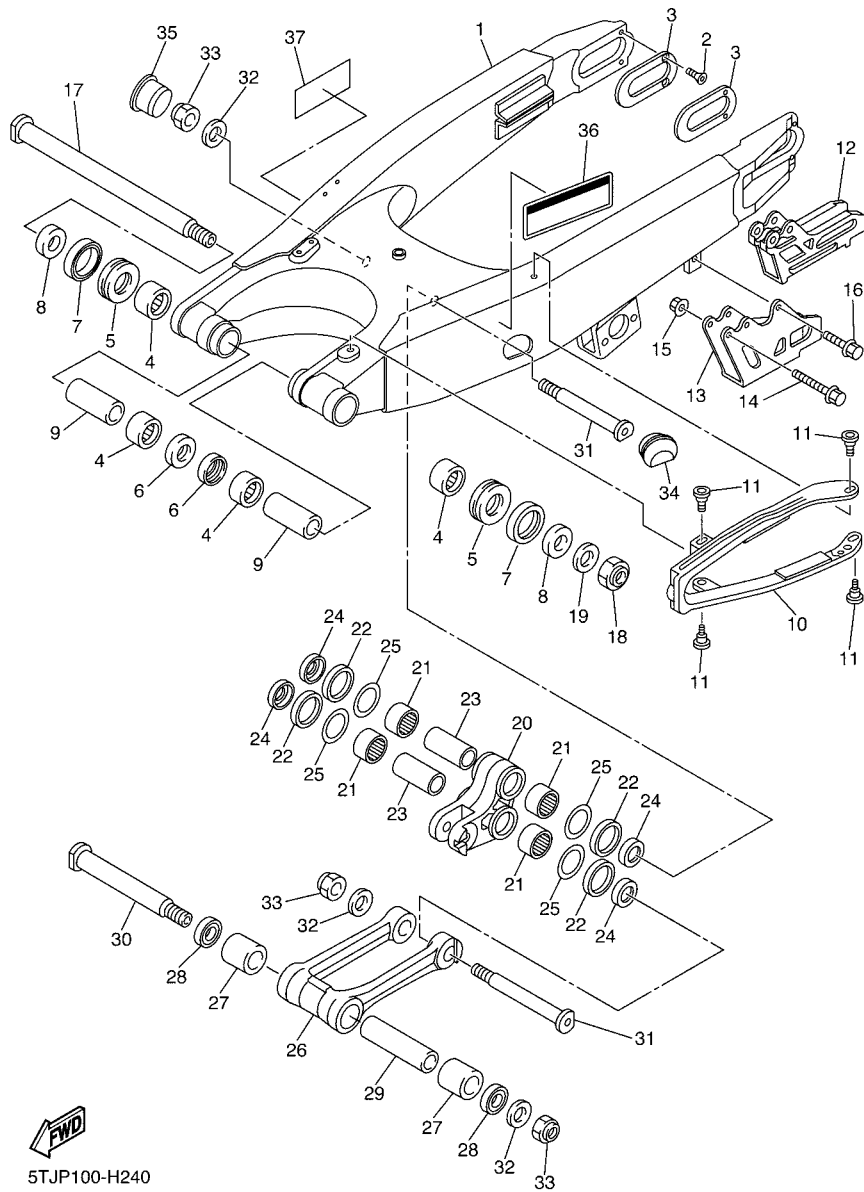

5TJP100-H240

FIG. 24 REAR ARM

REF. NO.	PART NO.	DESCRIPTION	5TJP	5TJR	5TJS	REMARKS
1	1C3-22110-90	REAR ARM COMP.	1	1	1	
2	90151-04003	SCREW, COUNTERSUNK	4	4	4	
3	1P8-22355-00	PATCH	2	2	2	
4	93317-22262	BEARING	4	4	4	
5	93342-22217	BEARING	2	2	2	
6	93106-22002	OIL SEAL	2	2	2	
7	93109-28043	OIL SEAL	2	2	2	
8	90387-18012	COLLAR	2	2	2	
9	90387-18004	COLLAR	2	2	2	
10	2S2-22151-70	SEAL, GUARD	1	1	1	
11	1C3-22969-90	SCREW, 1	4	4	4	
12	5UM-22199-E0	SUPPORT, CHAIN	1	1	1	
13	2S2-22128-70	COVER, THRUST 1	1	1	1	
14	90105-06104	BOLT, FLANGE	2	2	2	
15	90179-06028	NUT	2	2	2	
16	90105-06105	BOLT, FLANGE	1	1	1	
17	1C3-22141-10	SHAFT, PIVOT	1	1	1	
18	90185-16002	NUT, SELF-LOCKING	1	1	1	
19	90201-16018	WASHER, PLATE	1	1	1	
20	5XC-2217A-90	ARM, RELAY	1	1	1	
21	93315-32166	BEARING	4	4	4	
22	93109-25001	OIL SEAL	4	4	4	
23	90387-16025	COLLAR	2	2	2	
24	90209-16011	WASHER	4	4	4	
25	90201-21014	WASHER, PLATE	4	4	4	
26	5XC-2217F-90	ROD, CONNECTING 1	1	1	1	
27	93315-32269	BEARING	2	2	2	

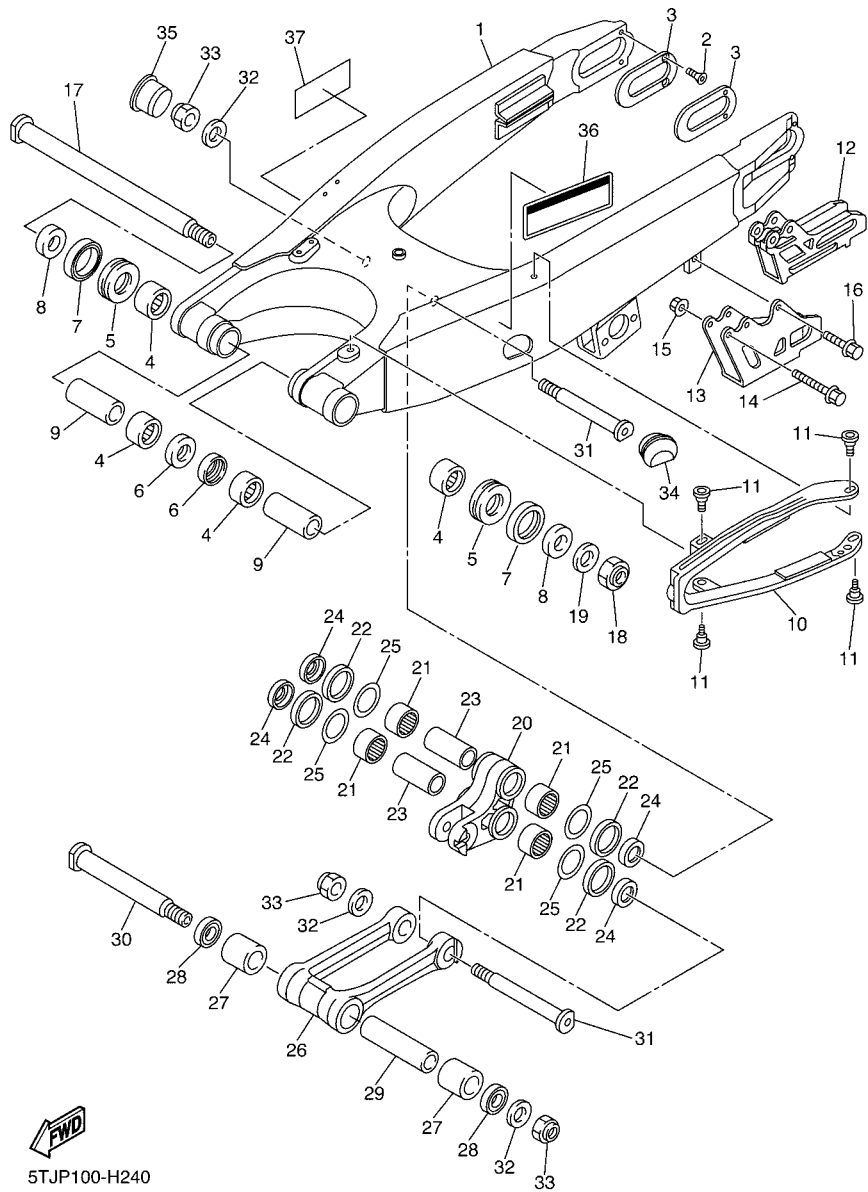

5TJP100-H240

FIG. 24 REAR ARM

REF. NO.	PART NO.	DESCRIPTION	5TJP	5TJR	5TJS	REMARKS
28	93109-22019	OIL SEAL	2	2	2	
29	90387-14009	COLLAR	1	1	1	
30	5XC-22121-91	SHAFT 1	1	1	1	
31	1C3-22122-00	SHAFT 2	2	2	2	
32	90201-14020	WASHER, PLATE	3	3	3	
33	90185-14010	NUT, SELF-LOCKING	3	3	3	
34	1C3-2135F-00	COVER	1	1	1	
35	1C3-2139R-00	COVER 2	1	1	1	
36	3RV-21668-A0	LABEL, TIRE	1	1	1	

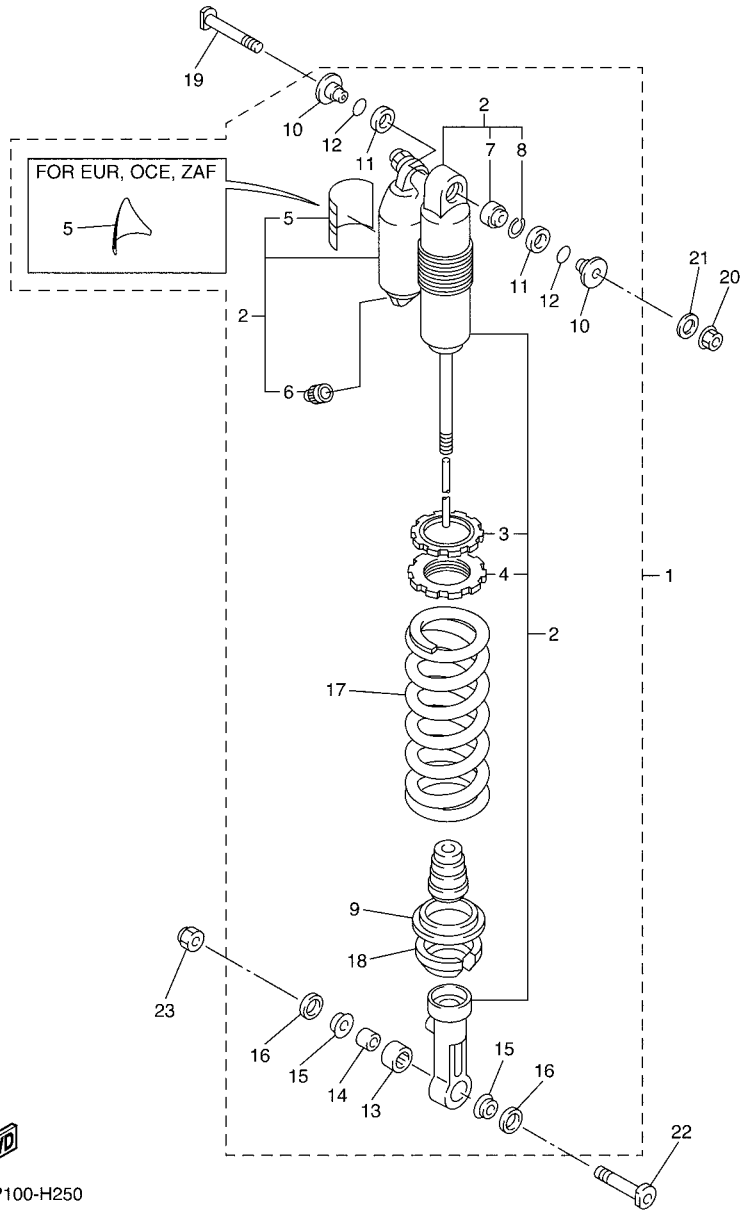

5TJP100-H250

FIG. 25 REAR SUSPENSION

REF. NO.	PART NO.	DESCRIPTION	5TJP	5TJR	5TJS	REMARKS
1	5TJ-22210-G0	SHOCK ABSORBER ASSY, REAR			1	
2	5TJ-22201-G0	.DAMPER SUB ASSY			1	
3	3SP-22234-00	..GUIDE, SPRING 3	1	1	1	
4	3SP-22213-00	..SEAT, SPRING UPPER	1	1	1	
5	4AA-22259-40	..LABEL, WARNING			1	
6	509-23184-L0	..CAP, AIR VALVE	1	1	1	
7	4JX-22226-00	..BUSH, SHOCK ABSORBER LOWER	1	1	1	
8	5DH-23183-00	..CIRCLIP	1	1	1	
9	5MV-22224-00	.GUIDE, SPRING 2	1	1	1	
10	1C3-22253-50	.COLLAR, DISTANCE	2	2	2	
11	3JE-22475-00	.SEAL, DUST	2	2	2	
12	4EW-22474-00	.SEAL, RING	2	2	2	
13	5UN-22176-00	.BEARING	1	1	1	
14	5MV-22184-00	.BUSH	1	1	1	
15	5MV-22253-00	.COLLAR, DISTANCE	2	2	2	
16	5NY-22475-00	.SEAL, DUST	2	2	2	
17	5UN-22212-60	.SPRING (K=54N/MM)	1	1	1	
18	5XE-22214-00	.GUIDE, SPRING 1	1	1	1	
19	5XE-22242-00	BOLT 2	1	1	1	
20	95602-10200	NUT, U FLANGE	1	1	1	
21	92902-10200	WASHER	1	1	1	
22	5NY-22241-00	BOLT 1	1	1	1	

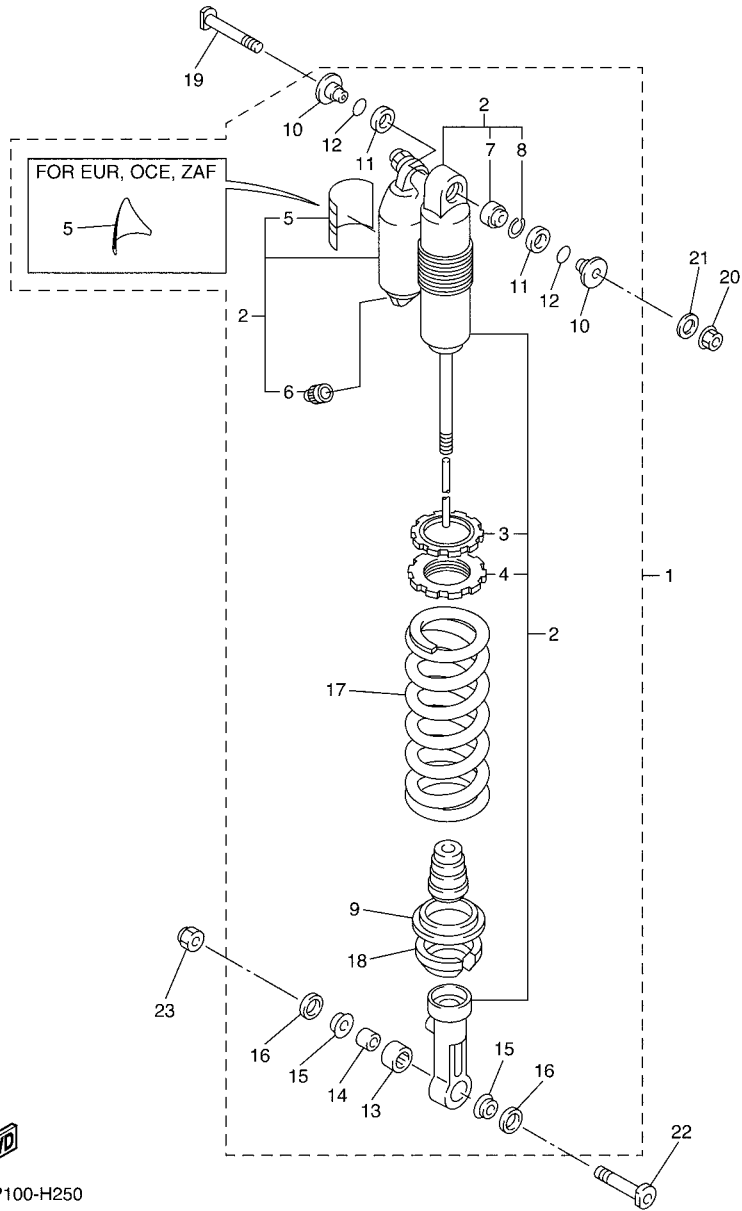
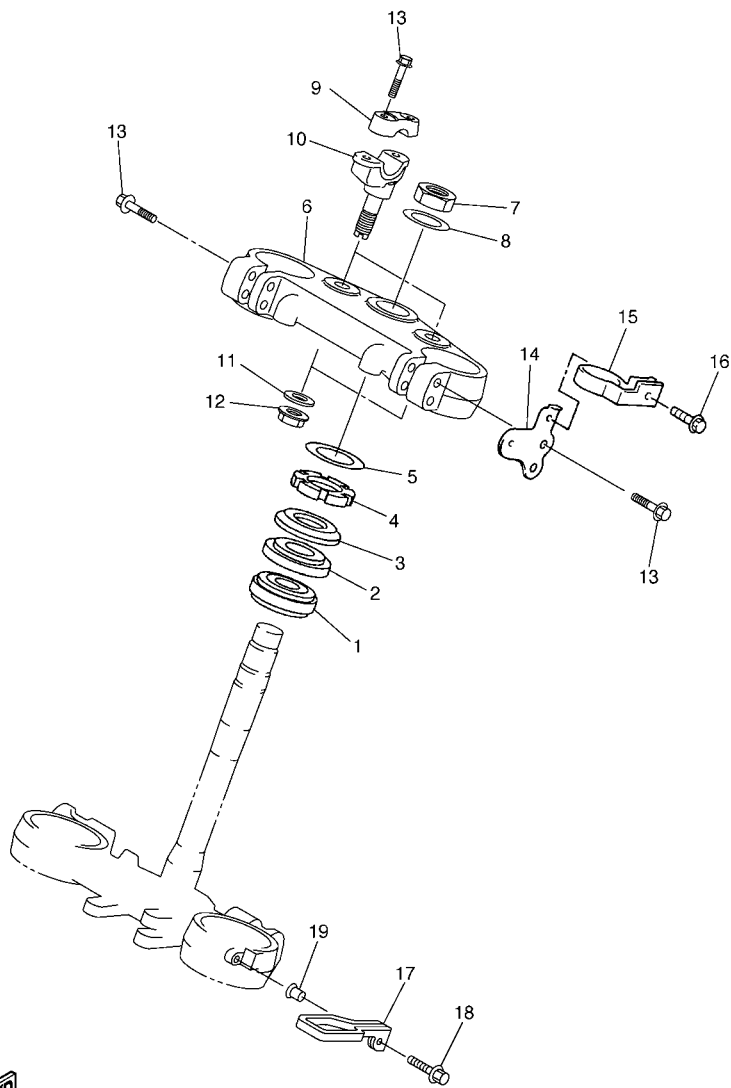

FIG. 25 REAR SUSPENSION

REF. NO.	PART NO.	DESCRIPTION	5TJP	5TJR	5TJS	REMARKS
23	90185-10012	NUT, SELF-LOCKING	1	1	1	



5TJE100-F260

FIG. 26 STEERING

REF. NO.	PART NO.	DESCRIPTION	5TJUP	5TJUR	5TJUS	REMARKS
1	93332-00081	BEARING	1	1	1	
2	93332-00068	BEARING	1	1	1	
3	4EW-23416-00	COVER, BALL RACE 2	1	1	1	
4	90179-28013	NUT	1	1	1	
5	90201-286K9	WASHER, PLATE (T1.0)	1	1	1	
6	5UM-23435-E1	CROWN, HANDLE	1	1	1	
7	90170-24003	NUT	1	1	1	
8	90201-24016	WASHER, PLATE	1	1	1	
9	5XC-23441-90	HOLDER, HANDLE UPPER	2	2	2	
10	5UM-23442-E0	HOLDER, HANDLE LOWER	2	2	2	
11	92902-10200	WASHER	2	2	2	
12	95602-10200	NUT, U FLANGE	2	2	2	
13	90105-08154	BOLT, FLANGE	8	8	8	
14	5UM-2831V-E0	STAY, HEAD LIGHT 1	1	1	1	
15	5TJ-2331E-80	GUIDE, CABLE	1	1	1	
16	90105-05016	BOLT, FLANGE	1	1	1	
17	5TJ-23389-80	GUIDE, CABLE	1	1	1	
18	90105-06107	BOLT, FLANGE	1	1	1	
19	90387-06104	COLLAR	1	1	1	

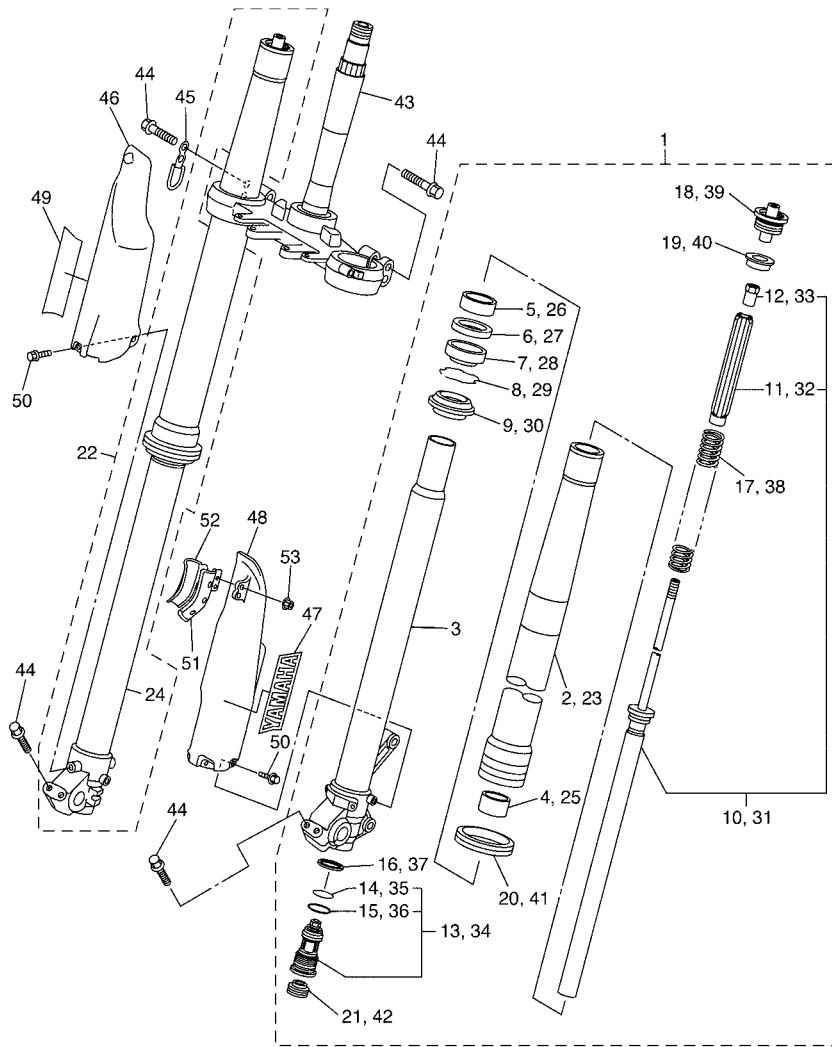

5TJP100-H270

FIG. 27 FRONT FORK

REF. NO.	PART NO.	DESCRIPTION	5TJP	5TJR	5TJS	REMARKS
1	5TJ-23102-F0	FRONT FORK ASSY (L.H)			1	
2	5TJ-23136-C0	.TUBE, OUTER (RIGHT)	1	1	1	
3	5TJ-23120-C0	.INNER TUBE COMP.2	1	1	1	
4	5XE-23171-L0	.PISTON, FRONT FORK	1	1	1	
5	5XE-23125-L0	.METAL, SLIDE 1	1	1	1	
6	5XE-23146-L0	.WASHER, OIL SEAL	1	1	1	
7	1C3-23145-L0	.OIL SEAL	1	1	1	
8	5XE-23153-L0	.RING, SNAP	1	1	1	
9	5XE-23144-L0	.SEAL, DUST	1	1	1	
10	5UM-23170-E0	.CYLINDER COMP., FRONT FORK	1	1	1	
11	5XE-23142-L0	..SEAT, SPRING UPPER	1	1	1	
12	5XE-23393-L0	..NUT, SPECIAL	1	1	1	
13	5TJ-2316A-F0	.VALVE COMP.	1	1	1	
14	5NY-23188-L0	..O-RING	1	1	1	
15	5NY-23147-L0	..O-RING	1	1	1	
16	4SS-23158-L0	.GASKET	1	1	1	
17	5TJ-23141-L0	.SPRING,FRONT FORK(K=4.5N/MM)	1	1	1	
18	5XE-23111-L0	.BOLT, CAP	1	1	1	
19	5XE-23117-L0	.GUIDE, SPRING	1	1	1	
20	1C3-2314F-M0	.PROTECTOR GUIDE COMP, 1	1	1	1	
21	3JD-2312G-L0	.PLUG	1	1	1	
22	5TJ-23103-F0	FRONT FORK ASSY (R.H)			1	
23	5TJ-23136-C0	.TUBE, OUTER (RIGHT)	1	1	1	
24	5TJ-23110-C0	.INNER TUBE COMP.1	1	1	1	
25	5XE-23171-L0	.PISTON, FRONT FORK	1	1	1	

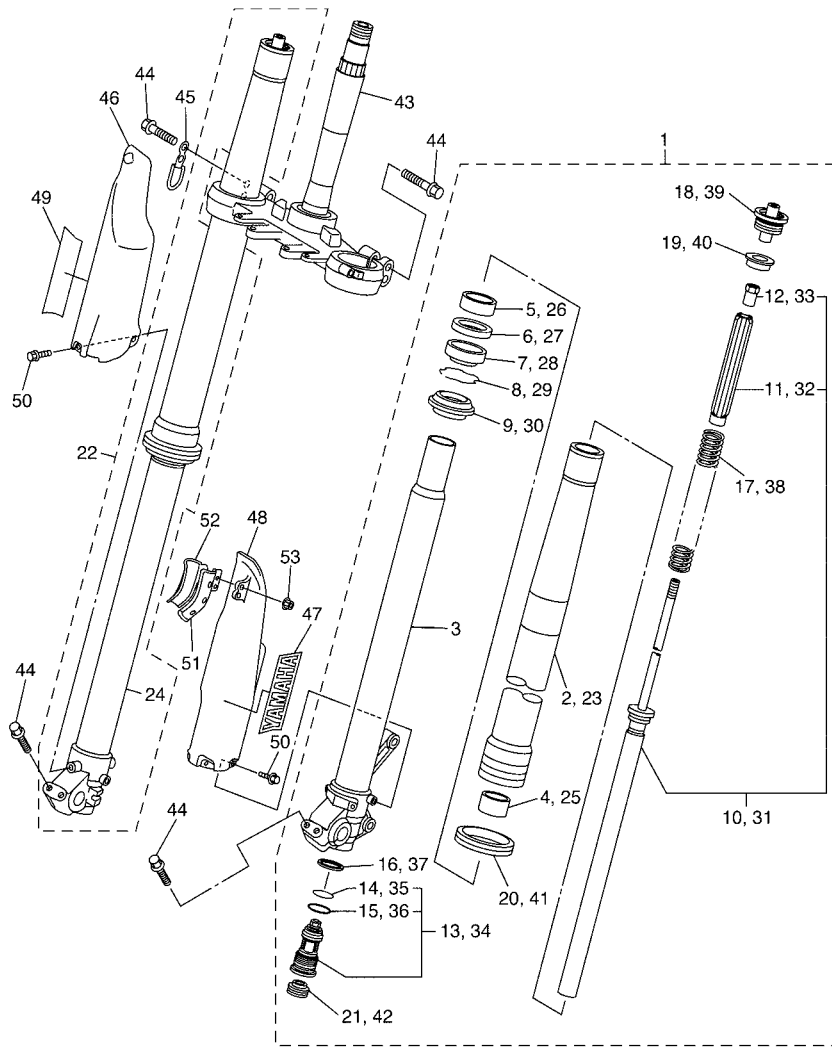

5TJP100-H270

FIG. 27 FRONT FORK

REF. NO.	PART NO.	DESCRIPTION	5TJP	5TJR	5TJS	REMARKS
26	5XE-23125-L0	.METAL, SLIDE 1	1	1	1	
27	5XE-23146-L0	.WASHER, OIL SEAL	1	1	1	
28	1C3-23145-L0	.OIL SEAL	1	1	1	
29	5XE-23153-L0	.RING, SNAP	1	1	1	
30	5XE-23144-L0	.SEAL, DUST	1	1	1	
31	5UM-23170-E0	.CYLINDER COMP., FRONT FORK	1	1	1	
32	5XE-23142-L0	..SEAT, SPRING UPPER	1	1	1	
33	5XE-23393-L0	..NUT, SPECIAL	1	1	1	
34	5TJ-2316A-F0	.VALVE COMP.	1	1	1	
35	5NY-23188-L0	..O-RING	1	1	1	
36	5NY-23147-L0	..O-RING	1	1	1	
37	4SS-23158-L0	.GASKET	1	1	1	
38	5TJ-23141-L0	.SPRING, FRONT FORK(K=4.5N/MM)	1	1	1	
39	5XE-23111-L0	.BOLT, CAP	1	1	1	
40	5XE-23117-L0	.GUIDE, SPRING	1	1	1	
41	1C3-2314F-M0	.PROTECTOR GUIDE COMP., 1	1	1	1	
42	3JD-2312G-L0	.PLUG	1	1	1	
43	5TJ-23340-M0	UNDER BRACKET COMP.	1	1	1	
44	90105-08134	BOLT, FLANGE	8	8	8	
45	5TJ-23525-C0	GUIDE	1	1	1	
46	5TJ-2315J-C0	PROTECTOR 2	1	1	1	
47	4XL-2153A-10	EMBLEM, YAMAHA	1	1	1	
48	1C3-2315H-10	PROTECTOR 1	1	1	1	
49	4XL-2153A-10	EMBLEM, YAMAHA	1	1	1	
50	3SP-23356-L0	BOLT 2	6	6	6	
51	5XC-23466-L0	CLAMP	1	1	1	
52	5XC-23467-L0	CLAMP	1	1	1	

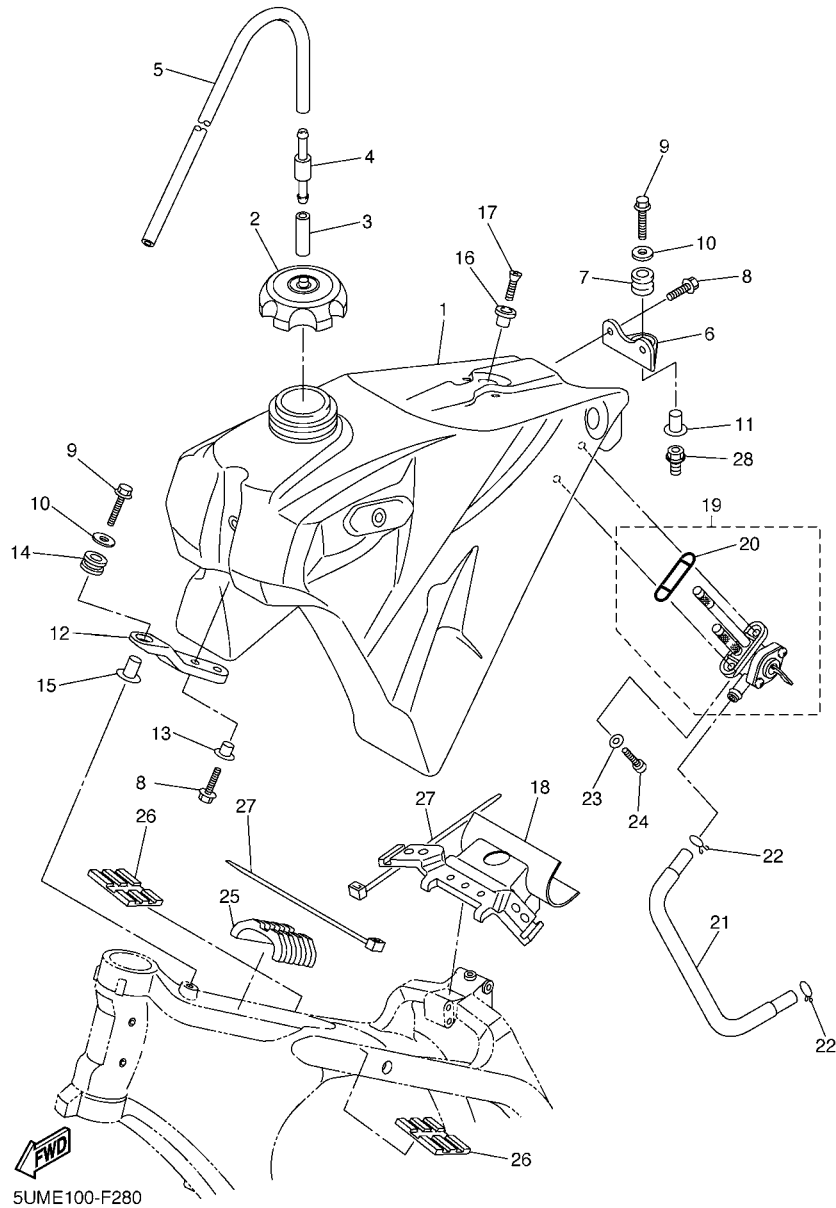

FIG. 28 FUEL TANK

REF. NO.	PART NO.	DESCRIPTION	5TUP	5TUR	5TUS	REMARKS
1	5UM-24110-E1	FUEL TANK COMP.			1	
2	5NY-24610-00	CAP ASSY	1	1	1	
3	90445-09220	HOSE (L30)			1	
4	3XJ-24380-00	PIPE JOINT ASSY	1	1	1	
5	90445-09251	HOSE (L350)	1	1	1	
6	5XE-24144-00	HOLDER, DAMPER	1	1	1	
7	90480-18549	GROMMET	1	1	1	
8	90105-06107	BOLT, FLANGE	4	4	4	
9	90105-06111	BOLT, FLANGE	2	2	2	
10	90201-06570	WASHER, PLATE	2	2	2	
11	3JD-24186-00	WASHER, SPECIAL	1	1	1	
12	5XC-2419A-90	HOLDER	1	1	1	
13	90387-06090	COLLAR	2	2	2	
14	5XC-24339-90	GROMMET	1	1	1	
15	90387-06065	COLLAR	1	1	1	
16	4EW-2412F-00	BRACKET, SEAT	1	1	1	
17	98702-06025	SCREW, FLAT HEAD	1	1	1	
18	5UM-24181-E0	DAMPER, LOCATING 1	1	1	1	
19	5UM-24500-E0	FUEL COCK ASSY 1	1	1	1	
20	1P6-24512-00	.O-RING	1	1	1	
21	5TJ-24311-E0	PIPE, FUEL 1			1	
22	90467-100A1	CLIP	2	2	2	
23	90202-05193	WASHER, PLATE	2	2	2	
24	90149-06108	SCREW	2	2	2	

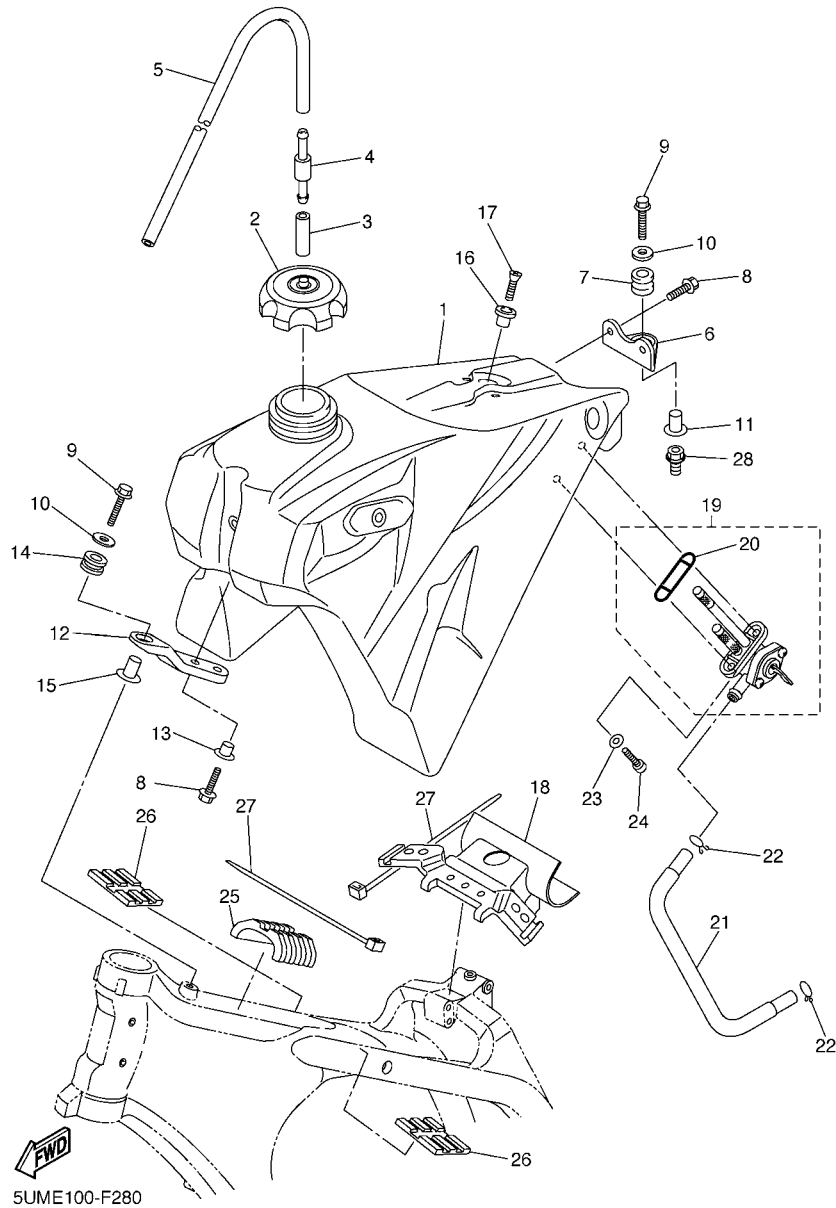
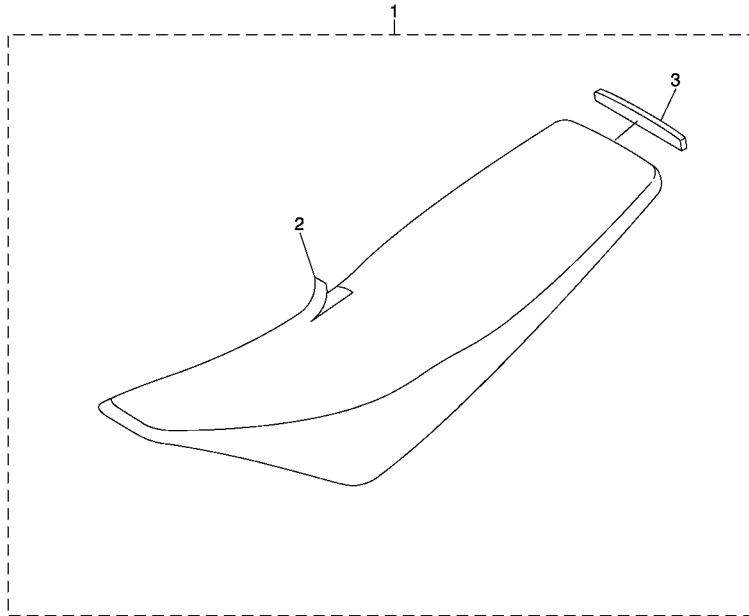

FIG. 28 FUEL TANK

REF. NO.	PART NO.	DESCRIPTION	5TUP	5TJR	5TJS	REMARKS
25	5XC-24182-90	DAMPER, LOCATING 2	1	1	1	
26	5XC-24183-90	DAMPER, LOCATING 3	2	2	2	
27	90465-13275	CLAMP	3	3	3	
28	1C3-21244-10	NUT	1	1	1	

FIG. 29 SEAT



REF. NO.	PART NO.	DESCRIPTION	5TJUP	5TJUF	5TJUS	REMARKS
1	5UM-24710-E0	SINGLE SEAT ASSY	1	1	1	
2	5UM-2470F-E0	.SEAT COVER COMP.	1	1	1	
3	5UM-24723-E0	.DAMPER, SEAT	1	1	1	



5TJE100-F290

FIG. 30 FRONT WHEEL

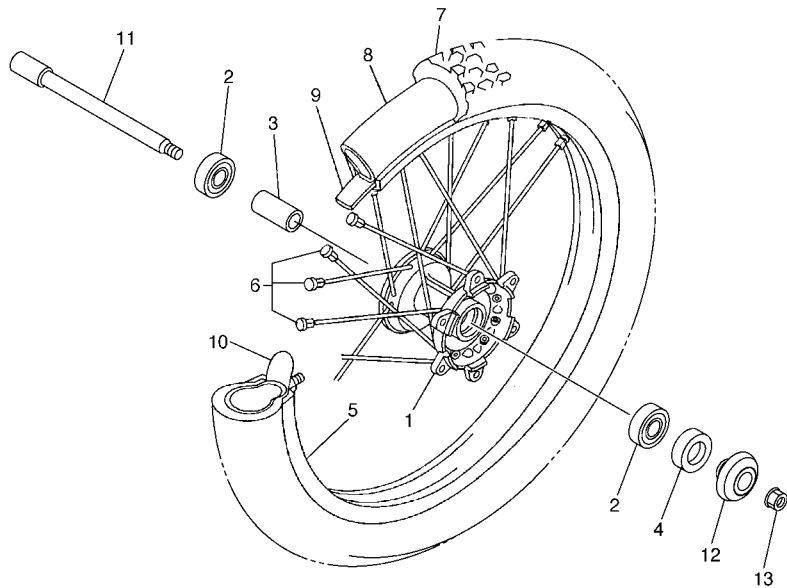

REF. NO.	PART NO.	DESCRIPTION	5TUP	5TJR	5TJS	REMARKS
1	5NG-25111-50	HUB, FRONT	1	1	1	
2	93306-90409	BEARING	2	2	2	
3	5NY-25117-00	SPACER, BEARING	1	1	1	
4	93102-26468	OIL SEAL	1	1	1	
5	94416-21018	RIM (1.60-21)	1	1	1	
6	5NY-25104-00	SPOKE SET, FRONT	1	1	1	
7	L.M.	TIRE (80/100-21 51M D739FA)			1	
8	L.M.	TUBE (80/100-21 M/C TR4)			1	
9	94309-21161	BAND, RIM (22-21)	1	1	1	
10	5SF-25394-00	SPACER, BEAD	1	1	1	
11	1C3-25181-10	AXLE, WHEEL	1	1	1	
12	5TJ-2510C-80	COLLAR ASSY.	1	1	1	
13	90179-16011	NUT	1	1	1	



5TJB100-E300

FIG. 31 FRONT BRAKE CALIPER

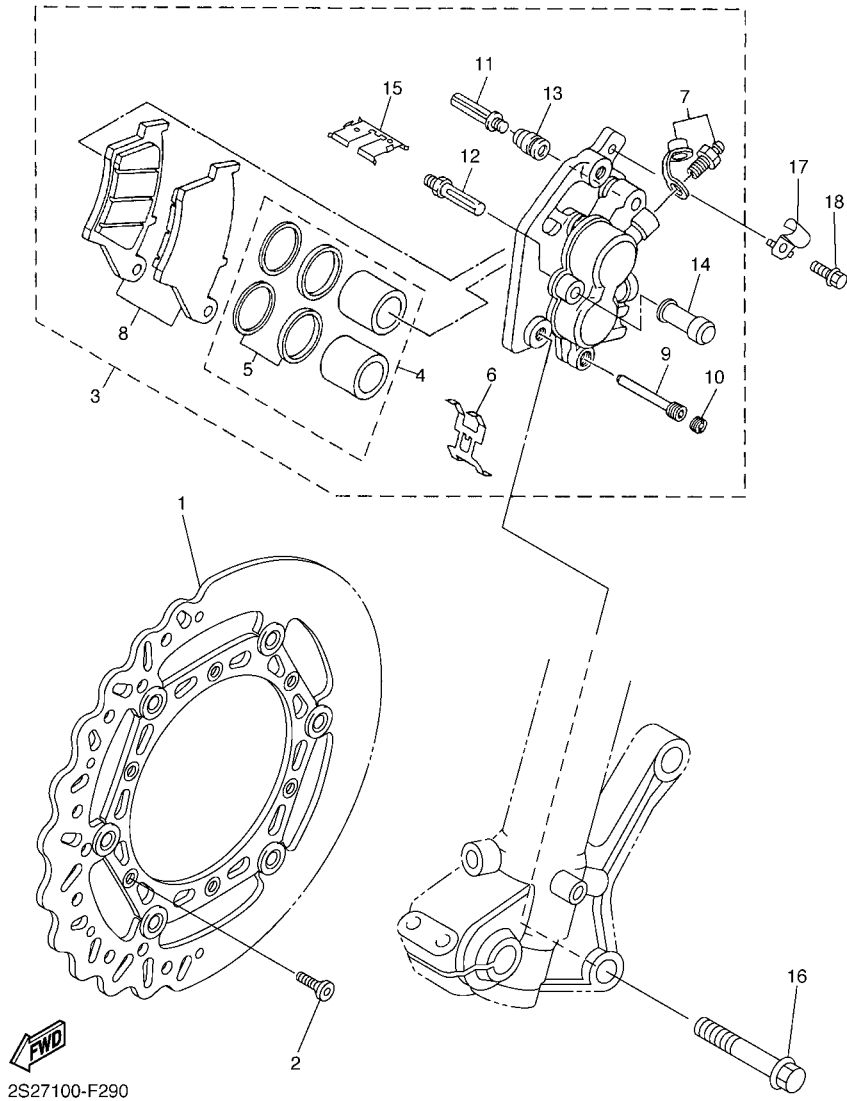

REF. NO.	PART NO.	DESCRIPTION	5TUP	5TJR	5TJS	REMARKS
1	2S2-2581T-70	DISK BRAKE ASSY	1	1	1	
2	90151-06051	SCREW, COUNTERSUNK	6	6	6	
3	1C3-2580T-00	CALIPER ASSY (LEFT)	1	1	1	
4	5UN-W0057-00	.PISTON ASSY, CALIPER	1	1	1	
5	3JD-W0047-00	..CALIPER SEAL KIT	1	1	1	
6	5DH-25919-00	.SUPPORT, PAD	1	1	1	
7	1UY-W0048-50	.BLEED SCREW KIT	1	1	1	
8	5MV-W0045-01	.BRAKE PAD KIT	1	1	1	
9	5DH-25933-00	.PIN, PAD	1	1	1	
10	5DH-25916-00	.PLUG	1	1	1	
11	3SP-25926-51	.BOLT	1	1	1	
12	3SP-25914-51	.PIN, SLIDE	1	1	1	
13	3JD-25917-00	.BOOT, CALIPER	1	1	1	
14	1UY-25937-51	.BOOT 2	1	1	1	
15	5DH-25849-00	.RETAINER, CALIPER	1	1	1	
16	90105-08137	BOLT, FLANGE	2	2	2	
17	1C3-25875-50	HOLDER, BRAKE HOSE 1	1	1	1	
18	90105-06105	BOLT, FLANGE	1	1	1	

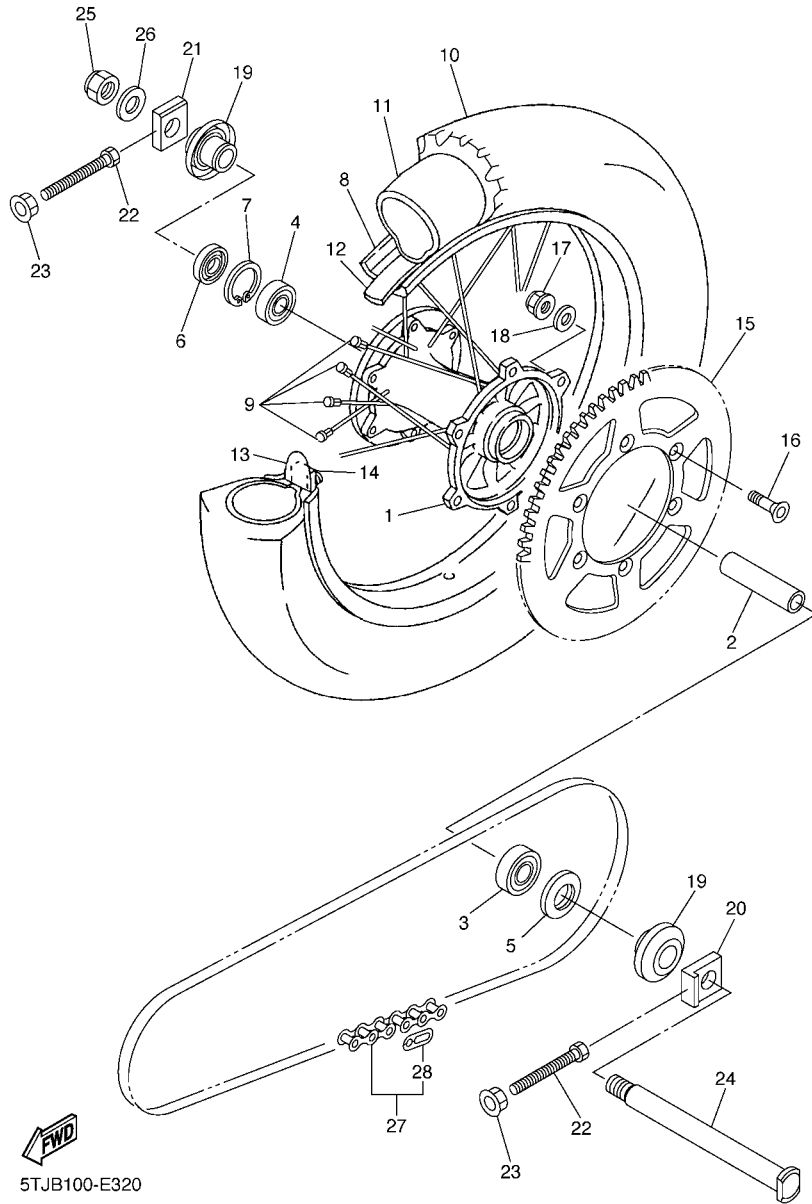

5TJB100-E320

FIG. 32 REAR WHEEL

REF. NO.	PART NO.	DESCRIPTION	5TJP	5TJR	5TJS	REMARKS
1	5ET-25311-00	HUB, REAR	1	1	1	
2	5ET-25317-00	SPACER, BEARING	1	1	1	
3	93306-27212	BEARING	1	1	1	
4	93306-07202	BEARING	1	1	1	
5	93106-30001	OIL SEAL	1	1	1	
6	93106-30045	OIL SEAL	1	1	1	
7	99009-45500	CIRCLIP	1	1	1	
8	94421-18008	RIM (2.15-18)	1	1	1	
9	5GS-25304-00	SPOKE SET, REAR	1	1	1	
10	L.M.	TIRE (110/100-18 64M D756)			1	
11	L.M.	TUBE (110-140/80-100-18 M/C)			1	
12	94309-18146	BAND, RIM (25-18)	1	1	1	
13	3JE-25394-00	SPACER, BEAD	2	2	2	
14	4XM-25364-00	DAMPER	2	2	2	
15	5TJ-25450-80	SPROCKET, DRIVEN (50T)	1		1	STD FOR CAN,ZAF
	1C3-25447-00	SPROCKET, DRIVEN (47T)			1	
	1C3-25450-00	SPROCKET, DRIVEN (50T)			1	STD FOR OCE
	5GS-25448-50	SPROCKET, DRIVEN (48T)	1	1	1	AP EXCEPT FOR OCE
	5TJ-25450-80	SPROCKET, DRIVEN (50T)			1	AP
	5TJ-25452-80	SPROCKET, DRIVEN (52T)	1	1	1	AP EXCEPT FOR OCE
	1C3-25448-00	SPROCKET, DRIVEN (48T)			1	AP FOR OCE
	1C3-25449-00	SPROCKET, DRIVEN (49T)			1	AP FOR OCE
	1C3-25451-00	SPROCKET, DRIVEN (51T)			1	AP FOR OCE
	1C3-25452-00	SPROCKET, DRIVEN (52T)			1	AP FOR OCE
16	90109-08078	BOLT	6	6	6	

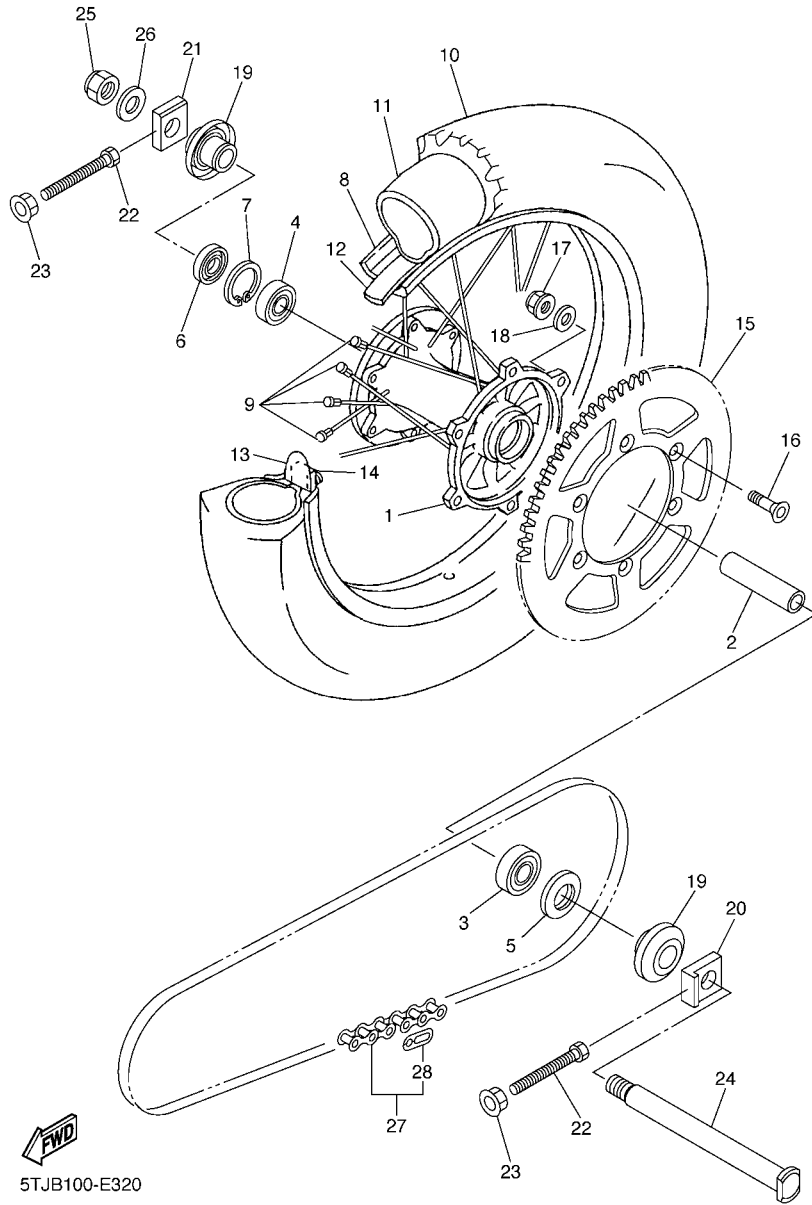

5TJB100-E320

FIG. 32 REAR WHEEL

REF. NO.	PART NO.	DESCRIPTION	5TJP	5TJR	5TJS	REMARKS
17	90185-08008	NUT, SELF-LOCKING	6	6	6	
18	90201-08048	WASHER, PLATE	6	6	6	
19	5TJ-2530S-80	COLLAR ASSY	2	2	2	
20	1C3-25388-H0	PULLER, CHAIN 1	1	1	1	
21	1C3-25389-H0	PULLER, CHAIN 2	1	1	1	
22	90101-08006	BOLT	2	2	2	
23	90179-08019	NUT	2	2	2	
24	1C3-25381-90	AXLE, WHEEL	1	1	1	
25	90185-20002	NUT, SELF-LOCKING	1	1	1	
26	90201-20020	WASHER, PLATE	1	1	1	
27	9Y58A-76113	CHAIN (DID 520VM-114LL)	1	1	1	
28	94681-76021	.JOINT, CHAIN (DID 520VM-ZJ)	1	1	1	

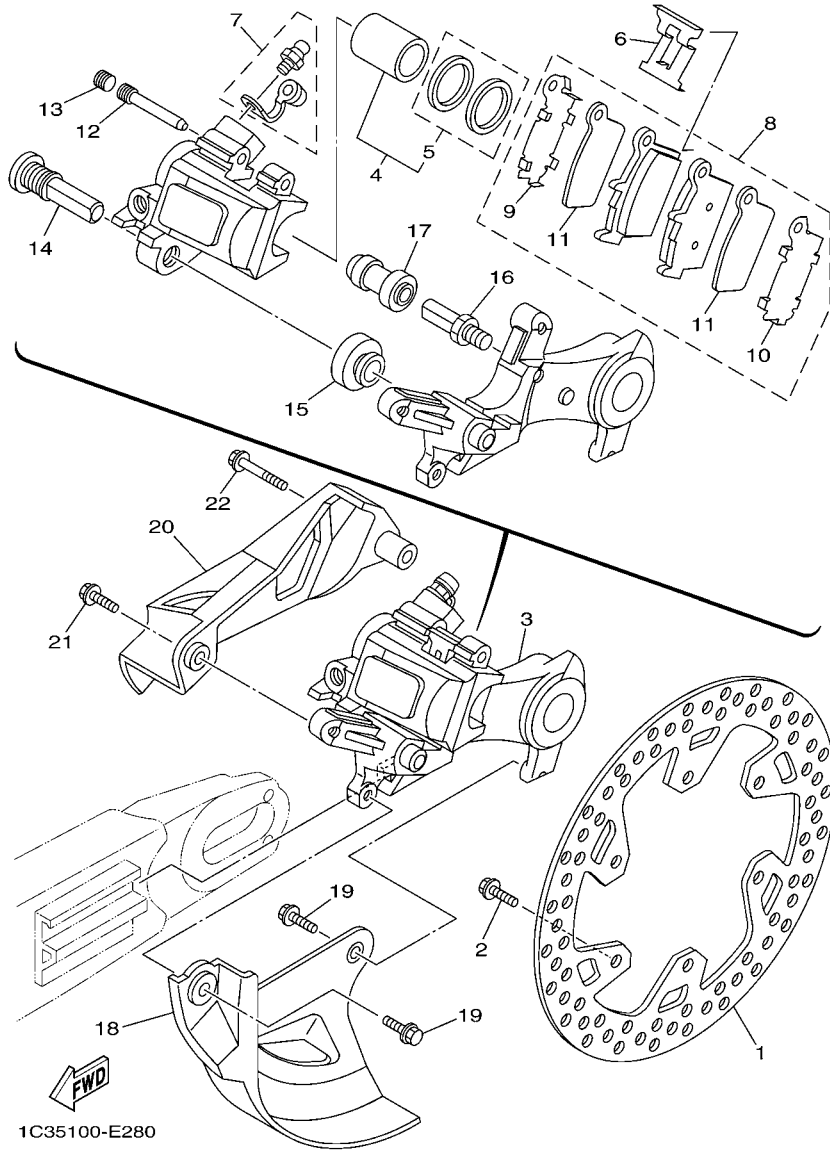
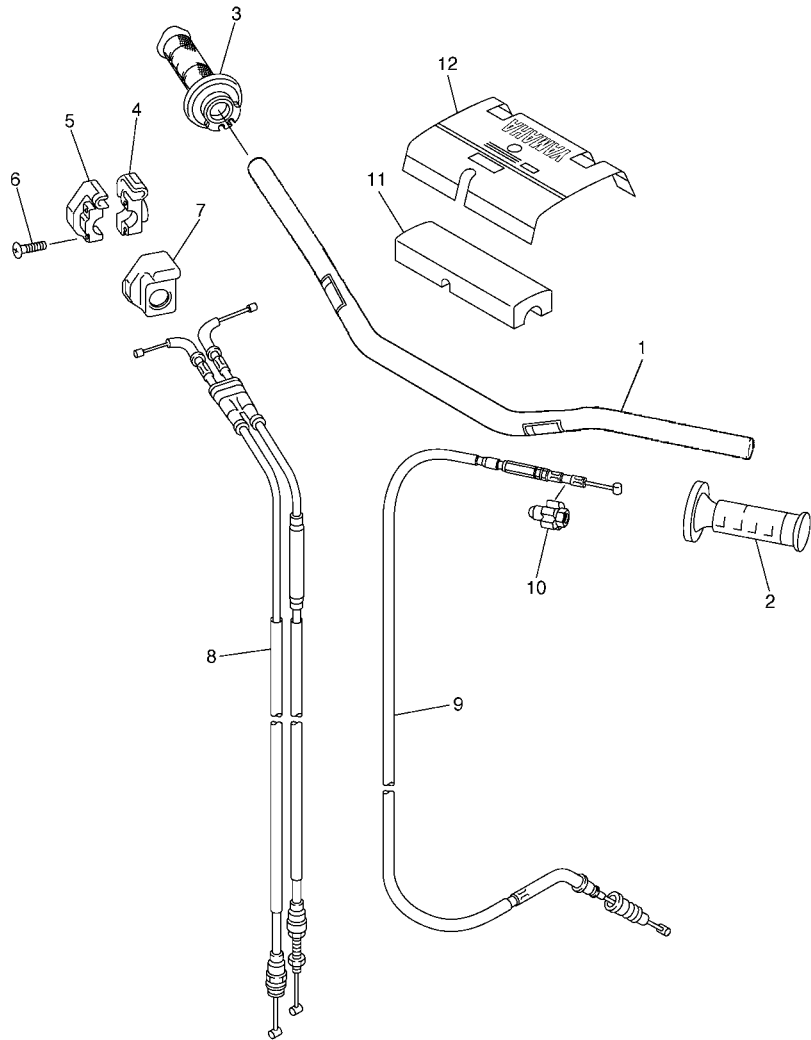

FIG. 33 REAR BRAKE CALIPER

REF. NO.	PART NO.	DESCRIPTION	5TUP	5TJR	5TJS	REMARKS
1	2S2-2582W-70	DISK, REAR BRAKE 2	1	1	1	
2	90105-06108	BOLT, FLANGE	6	6	6	
3	1C3-2580W-72	CALIPER ASSY, REAR 2	1	1	1	
4	5UN-W0057-50	.PISTON ASSY, CALIPER	1	1	1	
5	5UN-W0047-50	..CALIPER SEAL KIT	1	1	1	
6	5DH-25919-50	..SUPPORT, PAD	1	1	1	
7	1UY-W0048-50	.BLEED SCREW KIT	1	1	1	
8	1C3-W0046-B0	.BRAKE PAD KIT 2	1	1	1	
9	5UN-25828-60	..SHIM, CALIPER	1	1	1	
10	5UN-25827-60	..SHIM, CALIPER	1	1	1	
11	5UN-22898-60	..INSULATOR, HEAT	2	2	2	
12	8CR-25924-00	.PIN, PAD	1	1	1	
13	5DH-25916-00	.PLUG	1	1	1	
14	5DH-25914-50	.PIN, SLIDE	1	1	1	
15	3JD-25917-00	.BOOT, CALIPER	1	1	1	
16	5UN-25914-00	.PIN, SLIDE	1	1	1	
17	1UY-25937-51	.BOOT 2	1	1	1	
18	1C3-25718-50	PROTECTOR, DISK BRAKE	1	1	1	
19	90105-06110	BOLT, FLANGE	2	2	2	
20	1C3-27491-50	PROTECTOR	1	1	1	
21	90105-06107	BOLT, FLANGE	1	1	1	
22	90105-06111	BOLT, FLANGE	1	1	1	



5TJE100-F340

FIG. 34 STEERING HANDLE & CABLE

REF. NO.	PART NO.	DESCRIPTION	5TJUP	5TJUR	5TJUS	REMARKS
1	5XC-26111-L0	HANDLEBAR	1	1	1	
2	4GY-26241-00	GRIP	1	1	1	
3	5TJ-26240-C0	GRIP ASSY	1	1	1	
4	5BE-26281-00	CAP, GRIP UPPER	1	1	1	
5	5BE-26282-00	CAP, GRIP UNDER	1	1	1	
6	98502-05020	SCREW, PAN HEAD	2	2	2	
7	5SF-26287-10	COVER, CAP GRIP	1	1	1	
8	5UM-26302-E0	THROTTLE CABLE ASSY	1	1	1	
9	5TJ-26335-E0	CABLE, CLUTCH	1	1	1	
10	1C3-26342-50	BOOT, CABLE	1	1	1	
11	5XC-26124-90	PROTECTOR, HANDLEBAR	1	1	1	
12	5XC-26143-L0	COVER, HANDLEBAR UPPER 1	1	1	1	



5XD5100-D331

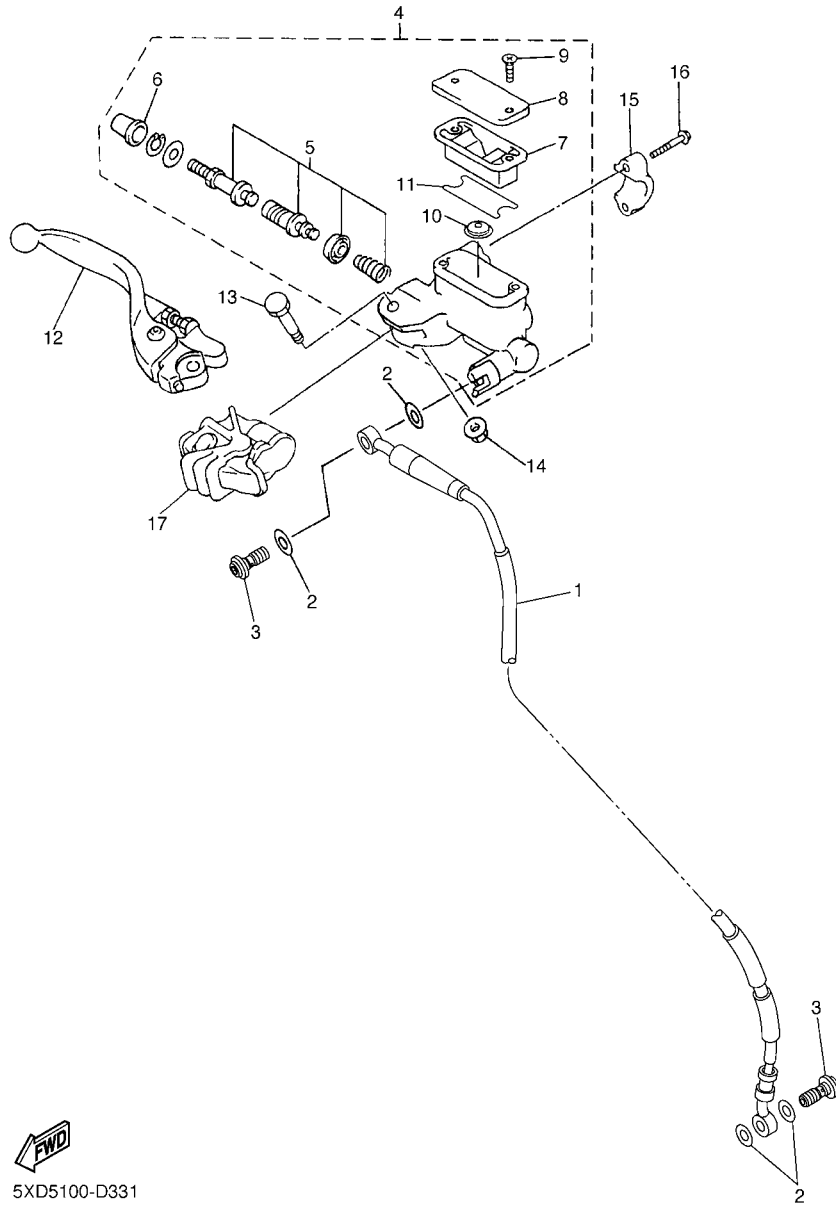
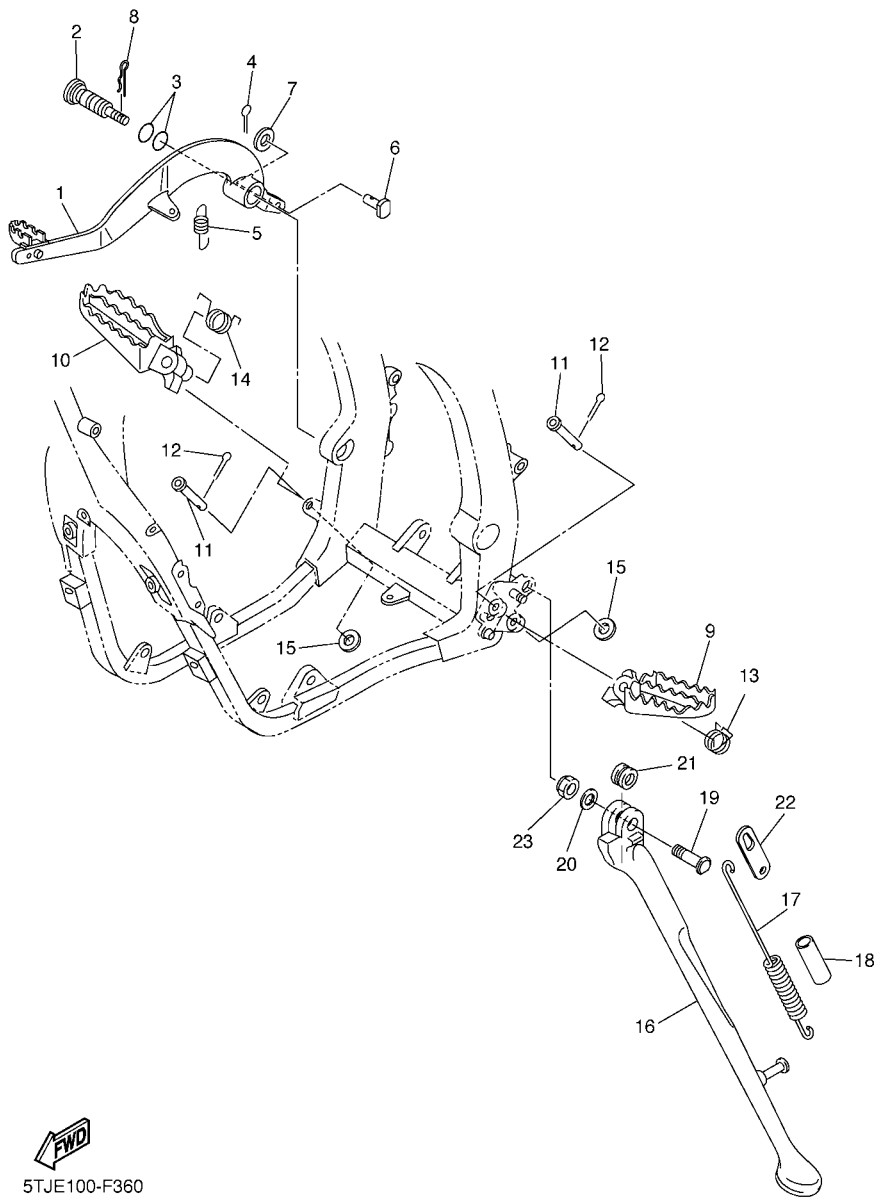

FIG. 35 FRONT MASTER CYLINDER

REF. NO.	PART NO.	DESCRIPTION	STUP	STUR	STUS	REMARKS
1	5TJ-25872-80	HOSE, BRAKE 1	1	1	1	
2	90430-10005	GASKET	4	4	4	
3	90401-10172	BOLT, UNION	2	2	2	
4	5XE-W2587-10	MASTER CYLINDER SUB ASSY	1	1	1	
5	5NY-W0041-00	.CYLINDER KIT, MASTER	1	1	1	
6	5NY-25868-00	.BOOT, MASTER CYLINDER	1	1	1	
7	5XE-25854-00	.GASKET, DIAPHRAGM	1	1	1	
8	5MV-25852-01	.CAP, RESERVOIR	1	1	1	
9	98706-04012	.SCREW, FLAT HEAD	2	2	2	
10	5CG-25715-00	.SEPARATOR ASSY	1	1	1	
11	5XE-25853-00	.FLOAT, RESERVOIR	1	1	1	
12	1C3-83922-50	LEVER 2	1	1	1	
13	5MV-2589F-00	BOLT, LEVER	1	1	1	
14	95701-06500	NUT, WITH WASHER	1	1	1	
15	5MV-25867-00	BRACKET, MASTER CYLINDER	1	1	1	
16	5MV-25833-00	BOLT, FITTING	2	2	2	
17	5NY-26372-00	COVER, HANDLE LEVER 1	1	1	1	

FIG. 36 STAND & FOOTREST

REF. NO.	PART NO.	DESCRIPTION	5TJUP	5TJUR	5TJUS	REMARKS
1	2S2-27200-10	PEDAL, BRAKE	1	1	1	
2	1C3-27217-10	BOLT	1	1	1	
3	93210-11073	O-RING	2	2	2	
4	91402-20012	PIN, COTTER	1	1	1	
5	90506-16007	SPRING, TENSION	1	1	1	
6	90240-08120	PIN, CLEVIS	1	1	1	
7	90201-08044	WASHER, PLATE	1	1	1	
8	90468-16001	CLIP	1	1	1	
9	5XC-27411-M1	FOOTREST 1	1	1	1	
10	5XC-27421-M1	FOOTREST 2	1	1	1	
11	90240-10004	PIN, CLEVIS	2	2	2	
12	91402-25015	PIN, COTTER	2	2	2	
13	90508-28015	SPRING, TORSION	1	1	1	
14	90508-28018	SPRING, TORSION	1	1	1	
15	90201-10032	WASHER, PLATE	2	2	2	
16	5UM-27311-E0	STAND, SIDE	1	1	1	
17	90506-30005	SPRING, TENSION	1	1	1	
18	90445-217G3	HOSE (L70)	1	1	1	
19	90109-10026	BOLT	1	1	1	
20	90201-10045	WASHER, PLATE	1	1	1	
21	90387-1003G	COLLAR	1	1	1	
22	5UM-27315-E0	LINK, SIDE STAND	1	1	1	
23	90185-10018	NUT, SELF-LOCKING	1	1	1	



5TJP100-H370

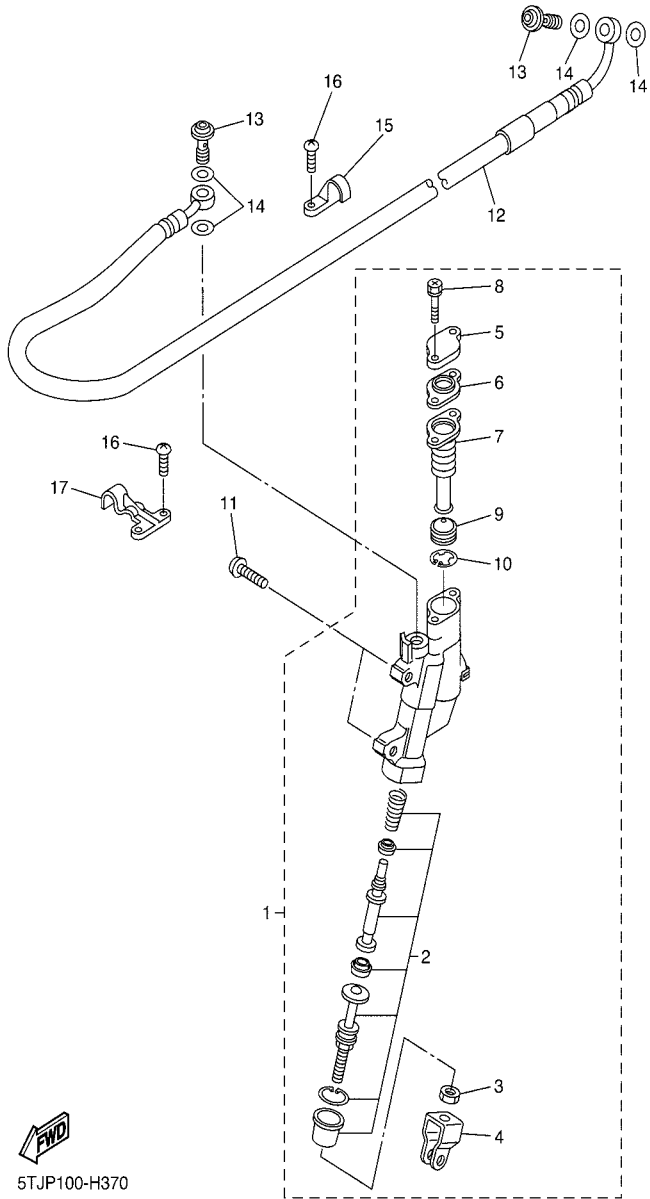
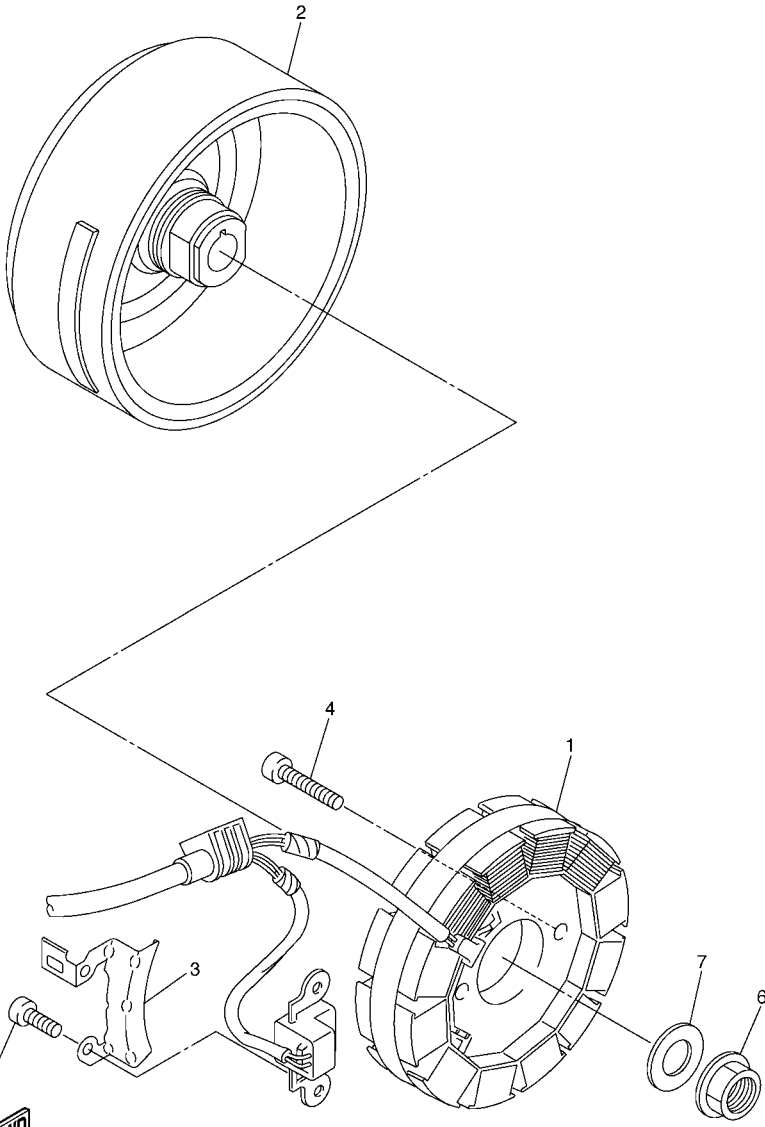

FIG. 37 REAR MASTER CYLINDER

REF. NO.	PART NO.	DESCRIPTION	5TJP	5TJR	5TJS	REMARKS
1	17D-2583V-00	RR. MASTER CYLINDER ASSY.	1	1	1	
2	5UN-W0042-50	.CYLINDER KIT, MASTER	1	1	1	
3	5UN-27218-00	.NUT	1	1	1	
4	5UN-27222-00	.JOINT	1	1	1	
5	5UN-25852-50	.CAP, RESERVOIR	1	1	1	
6	5UN-2585B-00	.PLATE, DIAPHRAGM	1	1	1	
7	5UN-25854-00	.GASKET, DIAPHRAGM	1	1	1	
8	5UN-27217-00	.BOLT	2	2	2	
9	5CG-25715-00	.SEPARATOR ASSY	1	1	1	
10	5CG-2585G-00	.CIRCLIP	1	1	1	
11	90111-06116	BOLT,HEX. SOCKET BUTTON	2	2	2	
12	5XC-25873-L0	HOSE, BRAKE 2	1	1	1	
13	90401-10172	BOLT, UNION	2	2	2	
14	90430-10005	GASKET	4	4	4	
15	1C3-25886-50	HOLDER, BRAKE HOSE	1	1	1	
16	98502-05010	SCREW, PAN HEAD	4	4	4	
17	1C3-25876-50	HOLDER, BRAKE HOSE 2	1	1	1	

FIG. 38 GENERATOR



5TJE100-F380

REF. NO.	PART NO.	DESCRIPTION	5TJP	5TJR	5TJS	REMARKS
1	5TJ-81410-50	STATOR ASSY	1	1	1	
2	5TJ-81450-30	ROTOR ASSY	1	1	1	
3	5TJ-81528-00	CLAMP 1	1	1	1	
4	90149-05024	SCREW	2	2	2	
5	90110-06248	BOLT, HEXAGON SOCKET HEAD	2	2	2	
6	90179-12657	NUT	1	1	1	
7	90201-12020	WASHER, PLATE	1	1	1	

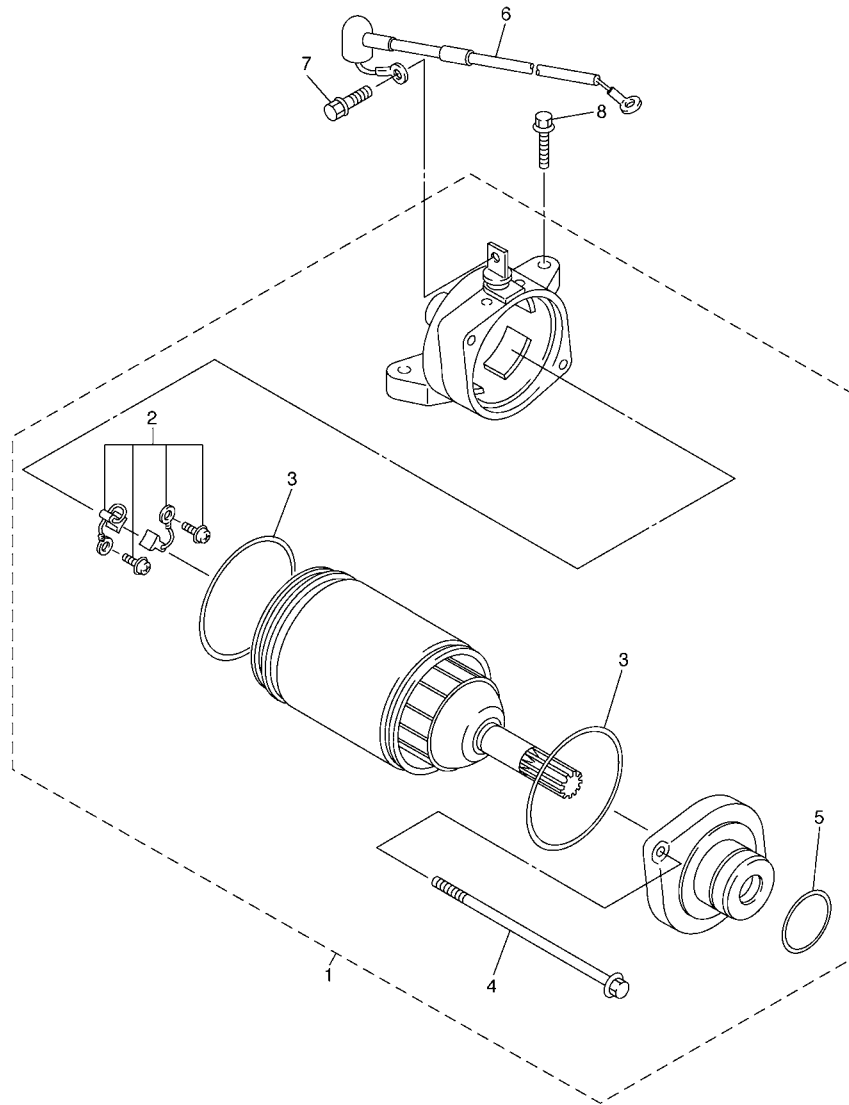
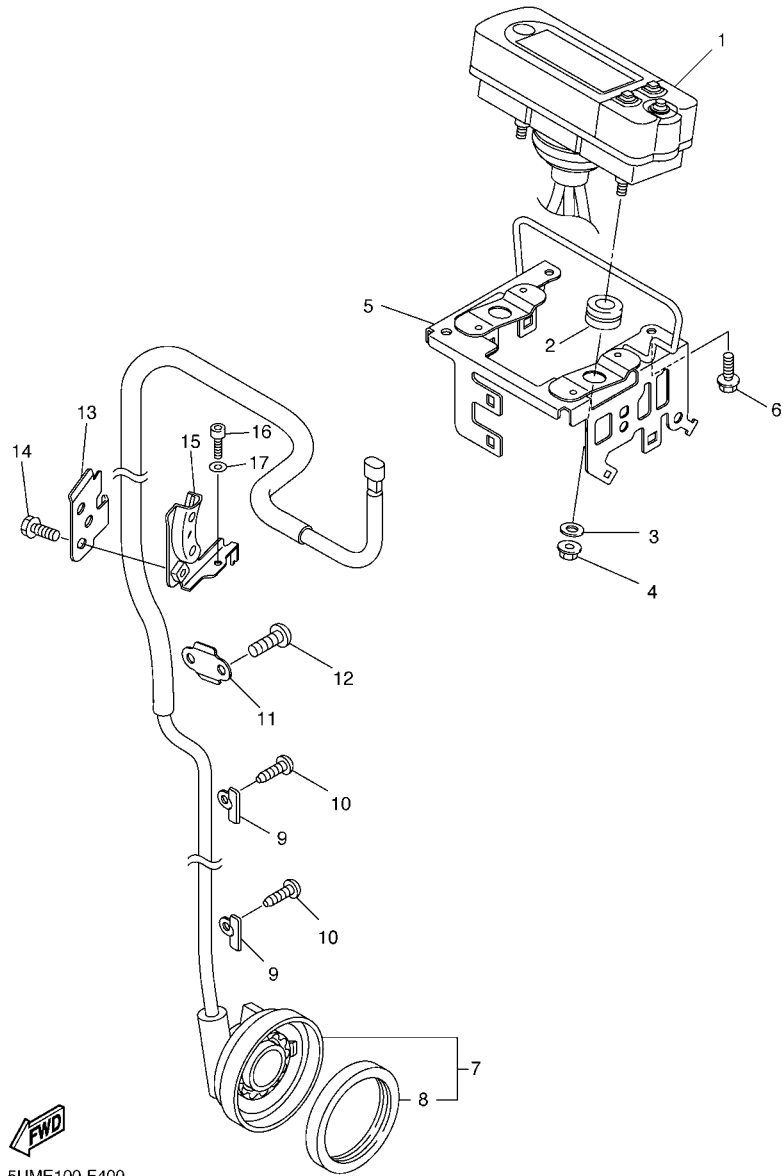

FIG. 39 STARTING MOTOR

REF. NO.	PART NO.	DESCRIPTION	5TJUP	5TJUR	5TJUS	REMARKS
1	5TJ-81890-30	MOTOR ASSY	1	1	1	
2	5TJ-81801-00	.BRUSH SET	1	1	1	
3	93210-44678	.O-RING	2	2	2	
4	50W-81846-M1	.SCREW	2	2	2	
5	93210-25711	.O-RING	1	1	1	
6	5TJ-8183G-30	CORD COMP.	1	1	1	
7	5TJ-81828-01	BOLT 2	1	1	1	
8	95022-06025	BOLT, FLANGE	2	2	2	



5TJE100-F390



FWD
5UME100-F400

FIG. 40 METER

REF. NO.	PART NO.	DESCRIPTION	5TJUP	5TJRF	5TJUS	REMARKS
1	5TJ-83500-F0	SPEEDOMETER ASSY (KM/H)	1	1	1	
2	90480-14012	GROMMET	2	2	2	
3	90201-05021	WASHER, PLATE	2	2	2	
4	95702-05500	NUT, WITH WASHER	2	2	2	
5	5UM-83519-E0	BRACKET, METER	1	1	1	
6	90105-06110	BOLT, FLANGE	2	2	2	
7	5TJ-83755-C0	SENSOR, SPEED	1	1	1	
8	93105-47007	.OIL SEAL	1	1	1	
9	5TJ-8375F-C0	PLATE 2	2	2	2	
10	97702-40010	SCREW, TAPPING	2	2	2	
11	5TJ-8375E-C0	PLATE 1	1	1	1	
12	92012-05008	BOLT, BUTTON HEAD	2	2	2	
13	5UM-83595-E0	CLAMP	1	1	1	
14	90105-06105	BOLT, FLANGE	1	1	1	
15	5UM-23591-E0	BRACKET 1	1	1	1	
16	92012-06012	BOLT, BUTTON HEAD	1	1	1	
17	92902-06600	WASHER, PLATE	1	1	1	

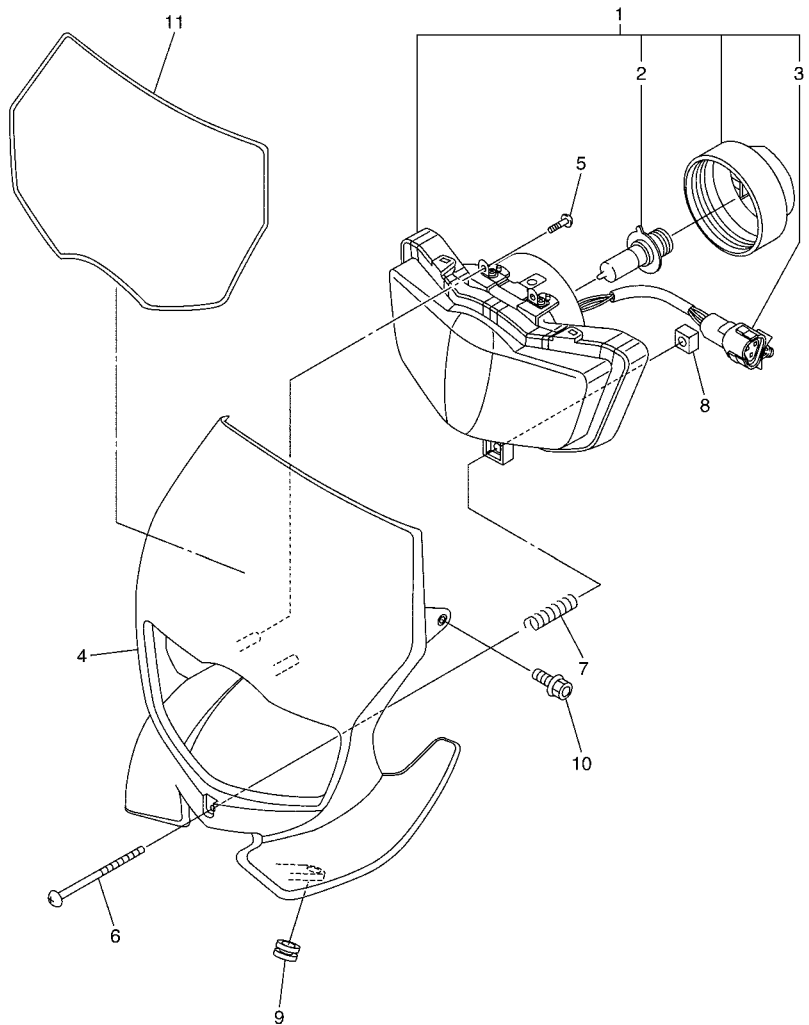

5TJJ100-G410

FIG. 41 HEADLIGHT

REF. NO.	PART NO.	DESCRIPTION	5TJP	5TJR	5TJS	REMARKS
1	5UM-84310-E1	HEADLIGHT UNIT ASSY	1	1	1	
2	5VM-84314-00	.BULB, HEADLIGHT(12V-35/36.5W)	1	1	1	HALOGEN
3	5UM-84340-E1	.SOCKET CORD ASSY 1	1	1	1	
4	5UM-84330-E0	BODY ASSY	1	1	1	
5	97702-50516	SCREW, TAPPING	2	2	2	
6	90157-04005	SCREW, PAN HEAD	1	1	1	
7	90501-120A3	SPRING, COMPRESSION	1	1	1	
8	5BF-84334-00	NUT, ADJUSTING	1	1	1	
9	90480-12020	GROMMET	2	2	2	
10	90105-06064	BOLT, FLANGE	2	2	2	
11	5TJ-2339E-00	GRAPHIC 1	1	1	1	

FIG. 42 TAILLIGHT

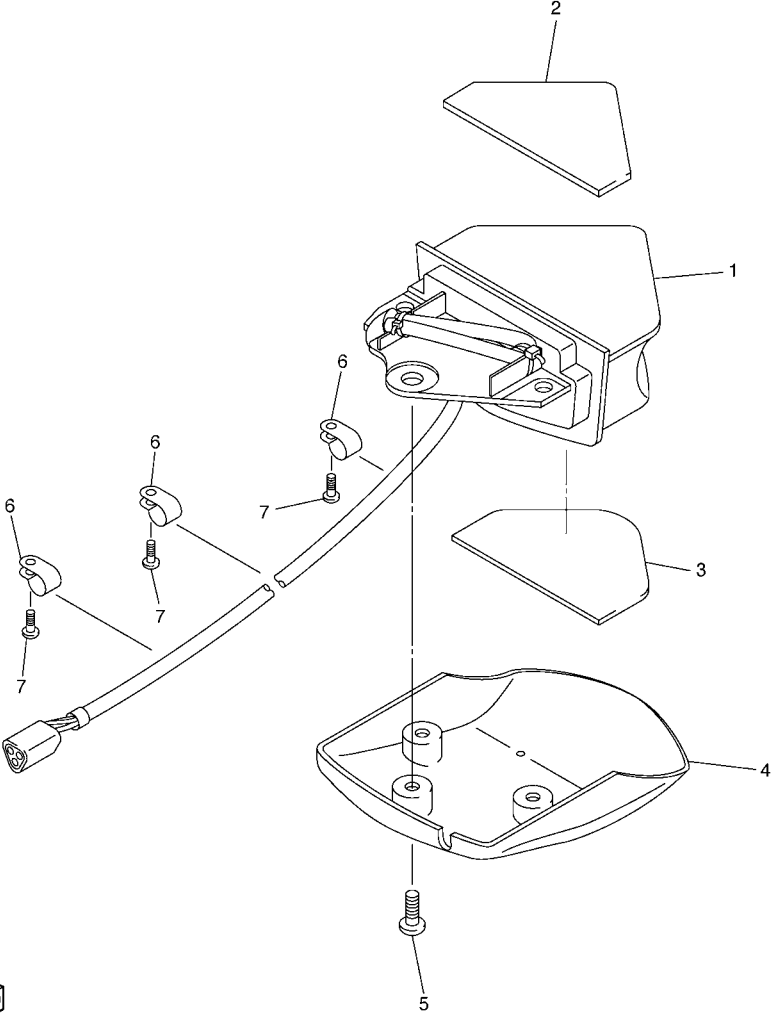

REF. NO.	PART NO.	DESCRIPTION	STUP	STUR	STUS	REMARKS
1	5UM-84710-E0	TAILLIGHT UNIT ASSY	1	1	1	
2	5UM-84736-E0	DAMPER, TAIL 1	1	1	1	
3	5UM-84737-E0	DAMPER, TAIL 2	1	1	1	
4	5UM-84716-E0	COVER, TAILLIGHT	1	1	1	
5	97702-50016	SCREW, TAPPING	3	3	3	
6	90464-11M18	CLAMP	3	3	3	
7	97702-40010	SCREW, TAPPING	3	3	3	



5UME100-F420

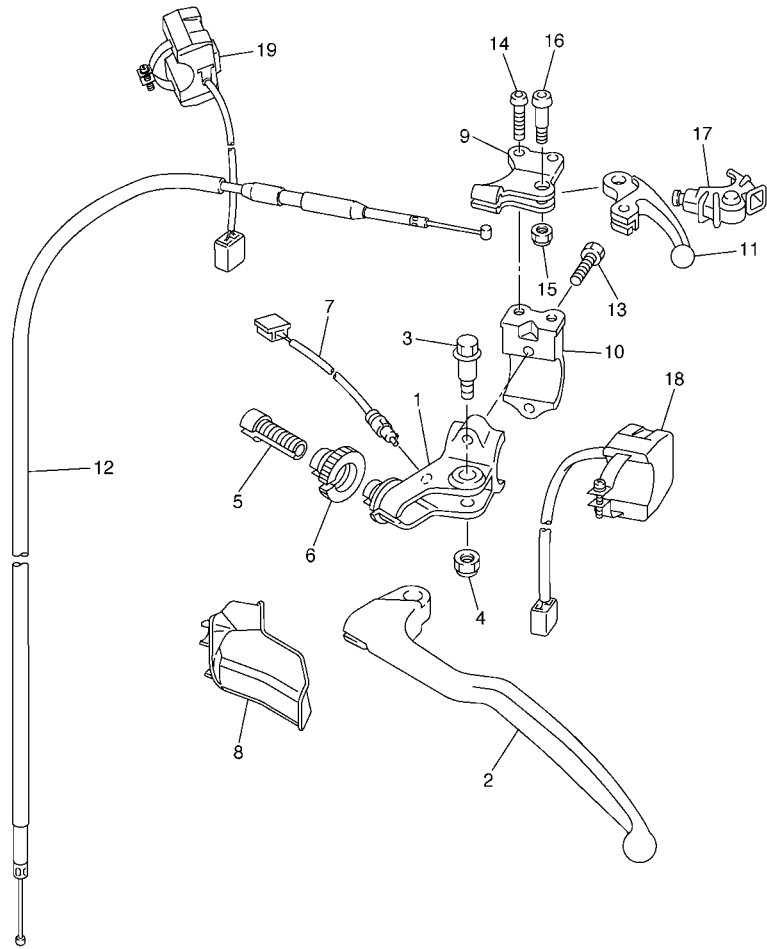

5UME100-F430

FIG. 43 HANDLE SWITCH & LEVER

REF. NO.	PART NO.	DESCRIPTION	5TJUP	5TJRF	5TJUS	REMARKS
1	5TJ-82911-80	HOLDER, LEVER 1	1	1	1	
2	5TJ-83912-80	LEVER 1	1	1	1	
3	90109-06034	BOLT	1	1	1	
4	5LP-84126-10	NUT, LENS FITTING	1	1	1	
5	5HD-26337-00	BOLT, ADJUSTING	1	1	1	
6	5HD-83951-00	BOLT, CABLE ADJUSTING	1	1	1	
7	5TJ-82917-02	SWITCH	1	1	1	
8	5TJ-26372-80	COVER, HANDLE LEVER 1	1	1	1	
9	5XD-82946-00	HOLDER, STARTER LEVER	1	1	1	
10	5XD-82913-00	HOLDER, LEVER LOWER 1	1	1	1	
11	5TA-83941-00	LEVER, STARTER	1	1	1	
12	5UM-26334-E0	CABLE, STARTER 2	1	1	1	
13	97002-05016	BOLT	2	2	2	
14	92012-05012	BOLT, BUTTON HEAD	2	2	2	
15	95602-05100	NUT, U	1	1	1	
16	90149-05162	SCREW	1	1	1	
17	5TA-26339-00	BOOT	1	1	1	
18	5UM-83976-E1	SWITCH, ENGINE STOP	1	1	1	
19	5UM-83976-F1	SWITCH, HANDLE 1	1	1	1	

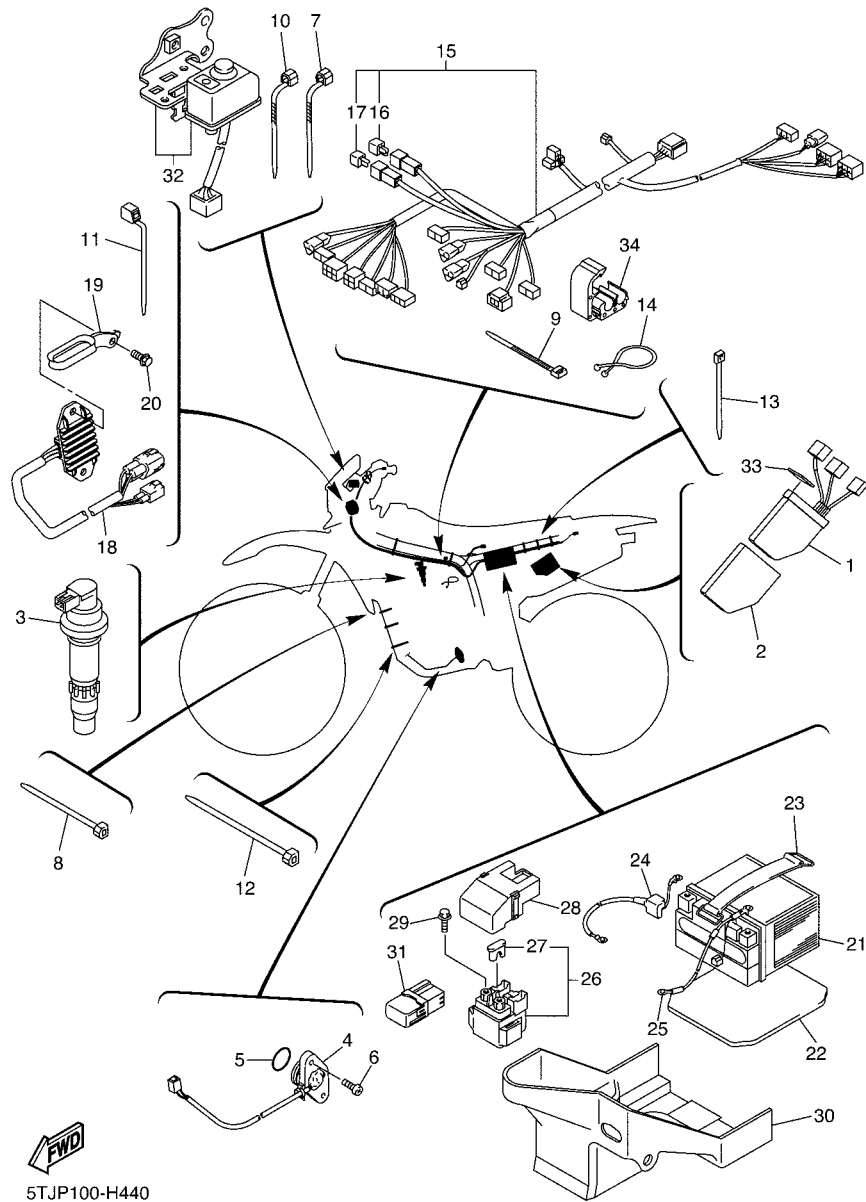

5TJP100-H440

FIG. 44 ELECTRICAL 1

REF. NO.	PART NO.	DESCRIPTION	5TJP	5TJR	5TJS	REMARKS
1	5TJ-85540-F0	C.D.I. UNIT ASSY			1	
2	5UM-85546-E0	BAND	1	1	1	
3	5TA-82310-10	IGNITION COIL ASSY	1	1	1	
4	5TJ-82540-01	NEUTRAL SWITCH ASSY	1	1	1	
5	93210-21001	O-RING	1	1	1	
6	90154-05022	SCREW, BINDING	2	2	2	
7	90464-13077	CLAMP	2	2	2	
8	90464-15152	CLAMP	3	3	3	
9	90465-13275	CLAMP	6	6	6	
10	90464-13073	CLAMP	3	3	3	
11	90464-16061	CLAMP	2	2	2	
12	90464-15195	CLAMP			3	
13	90465-13152	CLAMP	5	5	5	
14	90464-23041	CLAMP	1	1	1	
15	5TJ-82590-F0	WIRE HARNESS ASSY			1	
16	5TJ-81980-00	.DIODE ASSY	1	1	1	
17	4WA-81980-00	.DIODE ASSY	1	1	1	
18	5UM-81960-E0	RECTIFIER & REGULATOR ASSY	1	1	1	
19	5UM-21288-E0	GUIDE, CABLE	1	1	1	
20	90105-06110	BOLT, FLANGE	2	2	2	
21	5TJ-82100-01	BATTERY ASSY (YTZ7S)	1	1	1	
22	5UM-82176-E0	DAMPER	1	1	1	
23	8CY-82131-00	BAND, BATTERY	1	1	1	

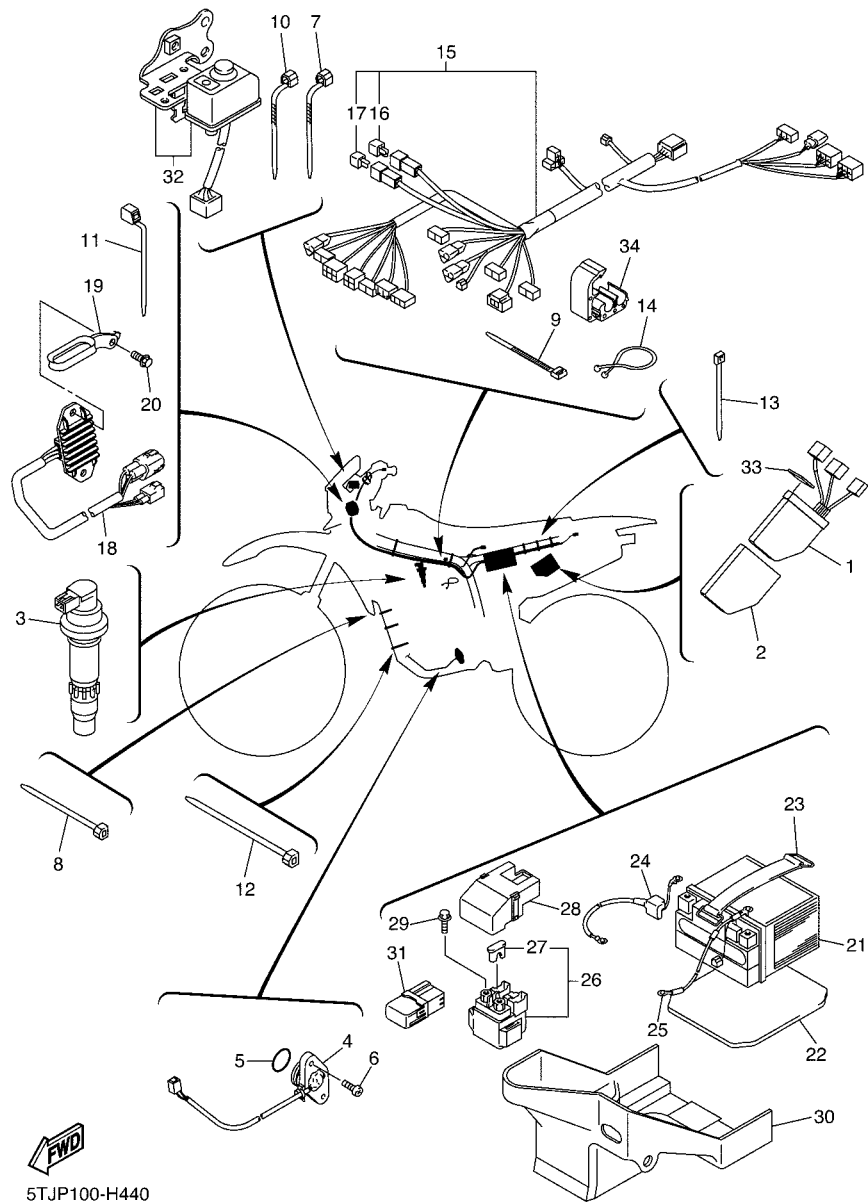

5TJP100-H440

FIG. 44 ELECTRICAL 1

REF. NO.	PART NO.	DESCRIPTION	5TJUP	5TJUR	5TJUS	REMARKS
24	5TJ-82115-00	WIRE, PLUS LEAD	1	1	1	
25	5TJ-82116-E0	WIRE, MINUS LEAD	1	1	1	
26	5TJ-81940-12	STARTER RELAY ASSY	1	1	1	
27	42X-82151-00	.FUSE (10A-BL)	2	2	2	
28	5SL-82119-10	COVER, LEAD WIRE	1	1	1	
29	95022-06008	BOLT, FLANGE	2	2	2	
30	5UM-81952-E0	HOLDER, RELAY	1	1	1	
31	5UM-81950-E0	RELAY ASSY	1	1	1	
32	5UM-82510-E1	MAIN SWITCH ASSY	1	1	1	
33	5UM-8235Y-E0	DAMPER	1	1	1	
34	90464-06004	CLAMP	1	1	1	
<hr/>						
<hr/>						
<hr/>						
<hr/>						
<hr/>						
<hr/>						
<hr/>						

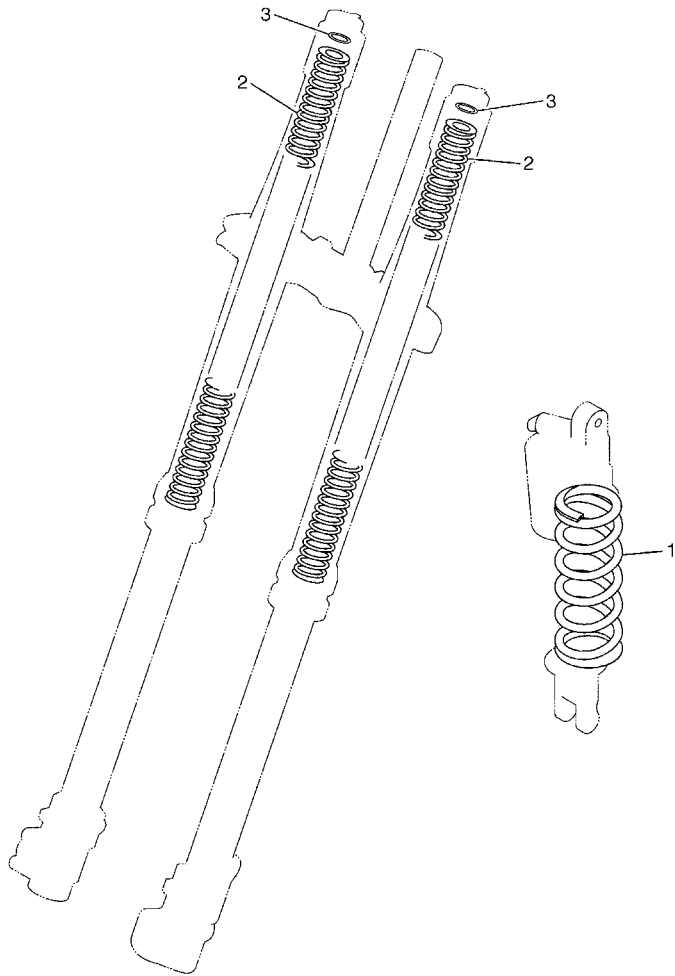

FIG. 45 ALTERNATE FOR CHASSIS

REF. NO.	PART NO.	DESCRIPTION	5TUP	5TJR	5TJS	REMARKS
1	5UN-22212-00	SPRING (K=42N/MM)	1	1	1	AP
	5UN-22212-10	SPRING (K=44N/MM)	1	1	1	AP
	5UN-22212-20	SPRING (K=46N/MM)	1	1	1	AP
	5UN-22212-30	SPRING (K=48N/MM)	1	1	1	AP
	5UN-22212-40	SPRING (K=50N/MM)	1	1	1	AP
	5UN-22212-50	SPRING (K=52N/MM)	1	1	1	AP
	5UN-22212-70	SPRING (K=56N/MM)	1	1	1	AP
2	5TJ-23141-00	SPRING (K=4.0N/MM)	1	1	1	AP
	5TJ-23141-10	SPRING (K=4.1N/MM)	1	1	1	AP
	5TJ-23141-20	SPRING (K=4.2N/MM)	1	1	1	AP
	5TJ-23141-30	SPRING (K=4.3N/MM)	1	1	1	AP
	5TJ-23141-40	SPRING (K=4.4N/MM)	1	1	1	AP
	5TJ-23141-60	SPRING (K=4.6N/MM)	1	1	1	AP
3	5XE-23364-00	COLLAR 2	1	1	1	AP



5XC1100-C390

NUMERICAL INDEX

PART NO.	REF. NO.	PART NO.	REF. NO.	PART NO.	REF. NO.	PART NO.	REF. NO.	PART NO.	REF. NO.	PART NO.	REF. NO.
5TJ-11101-10	1 - 1	3LD-12168-M1	3 - 13	2S2-13412-00	7 - 12	5UM-14451-E0	9 - 17	5TJ-14916-AM	10 - 12	3TJ-1494F-15	10 - 20
5TJ-11126-00	9 - 43	3LD-12168-R1	3 - 13	5D3-13440-00	8 - 1	5TJ-14453-E0	9 - 13	5TJ-14916-AN	10 - 12	5JG-14951-00	10 - 6
5TA-11133-10	1 - 3	3LD-12168-U1	3 - 13	5BE-13447-20	8 - 2	5TJ-14453-L0	9 - 13	5TJ-14916-AP	10 - 12	5GS-14958-00	10 - 63
5TA-11134-10	1 - 4	3LD-12168-W1	3 - 13	2S2-13597-00	9 - 1	5NY-14455-20	9 - 15	5TJ-14916-AR	10 - 12	5JG-14959-00	10 - 2
5TJ-11166-10	1 - 21	3LD-12168-Y1	3 - 13	5TJ-14101-E0	10 - 1	5TJ-14458-00	9 - 20	5TJ-14916-AS	10 - 12	5JG-14984-00	10 - 28
3P6-11167-00	1 - 20	3LD-12169-11	3 - 13	5TJ-14101-L0	10 - 1	5TJ-14459-01	9 - 14	5TJ-14916-AT	10 - 12	4SR-14985-00	10 - 24
5TJ-11167-10	9 - 42	3LD-12169-31	3 - 13	5NL-14105-00	10 - 23	5UM-14462-E0	9 - 30	5TJ-14916-LU	10 - 12	5TA-14987-00	9 - 8
2S2-11181-00	1 - 14	3LD-12169-50	3 - 13	4MX-14115-00	10 - 50	5TJ-14475-00	9 - 18	5TJ-14916-NT	10 - 12	5TJ-14987-00	10 - 56
2S2-11190-20	1 - 17	3LD-12169-70	3 - 13	3TJ-14137-40	9 - 9	5JG-14521-00	10 - 14	5XC-14922-00	10 - 43	5TA-14991-00	10 - 38
2S2-11193-00	1 - 23	3LD-12169-90	3 - 13			5JG-14522-00	10 - 7	5GS-14933-00	10 - 64	4FN-14997-00	10 - 11
5UM-1119E-00	1 - 19	3LD-12169-E0	3 - 13	5BE-14146-00	10 - 52	5JG-14531-00	10 - 59	5GS-14933-40	10 - 33	5TA-14997-00	10 - 41
2S2-11311-10	1 - 24	3LD-12169-G0	3 - 13	5PA-14146-00	10 - 61	3TJ-14536-40	10 - 32	5TA-14934-00	10 - 45	2S2-15100-11	13 - 1
2S2-11351-00	1 - 25	3LD-12169-J0	3 - 13	5TA-14155-00	10 - 40	5JG-14546-01	10 - 10	5GS-14940-00	10 - 62	2S2-15155-10	13 - 2
5TJ-11400-20	2 - 1	3LD-12169-L0	3 - 13	633-14159-00	10 - 27	676-14548-00	10 - 25	5JG-14940-17	10 - 31	3Y1-15363-00	14 - 6
5TJ-11412-20	2 - 2	3LD-12169-N0	3 - 13	3TJ-14159-40	10 - 13	4MX-14561-00	10 - 49	5JG-14940-18	10 - 31	2S2-1536A-00	13 - 27
2S2-11422-00	2 - 3	3LD-12169-T0	3 - 13	5XC-14171-00	10 - 35	6H4-14561-00	10 - 34	5JG-14940-19	10 - 31	5XC-15373-00	13 - 3
2S2-11454-00	2 - 14	5TJ-12170-00	4 - 1	3TJ-14191-40	10 - 29	5NX-14562-00	10 - 47	5TA-14943-15	10 - 21		14 - 21
2S2-11455-00	2 - 9	5TJ-12180-30	4 - 2	5UL-14196-00	10 - 54	3TJ-14564-40	10 - 66	4MX-14943-39	10 - 18	4JT-15381-01	13 - 13
2S2-11464-00	2 - 16	5TA-12210-10	4 - 5	5TA-14197-00	10 - 55	5JG-14565-00	10 - 58	4MX-14943-40	10 - 18	5BE-15383-01	13 - 14
2S2-11531-00	2 - 11	4FM-12213-00	4 - 6			5TJ-14591-10	10 - 60	4MX-14943-41	10 - 18	2S2-15388-00	13 - 17
2S2-11536-00	2 - 8	5BE-12241-00	1 - 18	5UM-14197-00	10 - 67	5TJ-14591-20	10 - 60	4MX-14943-42	10 - 18	5TJ-15411-30	14 - 1
5JG-11603-00	2 - 22	2S2-12251-00	4 - 9	2S2-14208-00	10 - 39	688-14592-00	10 - 4	4MX-14943-43	10 - 18	5TA-15415-20	14 - 26
2S2-11631-20	2 - 21	5TA-12252-00	4 - 10	5NX-14216-00	10 - 48	5TJ-14611-10	12 - 1	4MX-14943-44	10 - 18	2S2-15421-10	13 - 8
5TA-11633-00	2 - 23	5TJ-12299-00	4 - 11	5TA-14227-00	9 - 6	3VD-14613-01	12 - 6	4MX-14943-90	10 - 18	2S2-15431-00	14 - 17
2S2-11651-00	2 - 6	5TJ-1240A-E0	6 - 1	5TA-14239-00	9 - 7	5TJ-14623-00	12 - 11		10 - 18	5TA-15441-01	13 - 32
5TG-11681-00	2 - 4	5BE-12422-20	5 - 7	5TA-14261-00	10 - 53	5TA-14628-00	12 - 2	4MX-14943-91	10 - 18	2S2-15451-00	14 - 8
5TA-12111-00	3 - 1	5BE-12439-00	5 - 8	5JG-14264-00	10 - 16	5TJ-14710-E0	12 - 8	4MX-14943-92	10 - 18	5TA-15453-00	14 - 27
5TA-12112-00	3 - 2	5UM-1244J-E0	23 - 26	3TJ-14267-40	10 - 9	5PH-14714-00	12 - 15	4MX-14943-93	10 - 18	2S2-15462-10	14 - 22
5TJ-12113-00	3 - 5	5DJ-12451-00	5 - 2	5JG-14275-00	10 - 15	5BE-14747-00	12 - 16	4MX-14943-94	10 - 18	5TJ-1549B-20	14 - 14
5TJ-12114-00	3 - 6	5GR-12458-00	5 - 1	5TJ-14291-00	9 - 2	4BD-14766-00	12 - 3	5TJ-14947-00	10 - 17	5TG-15515-01	16 - 6
4GY-12117-00	3 - 8	2S2-12461-70	6 - 5	5TA-14293-00	9 - 5	5TJ-14780-00	12 - 9	4MX-14948-05	10 - 19	5TJ-15517-00	16 - 5
5BE-12117-00	3 - 7	22W-12462-00	6 - 9	3TJ-14293-40	10 - 30	5TJ-14784-00	12 - 10		10 - 19	4GY-15521-00	16 - 4
1AA-12118-00	3 - 9	2S2-12464-70	6 - 2	5TA-14335-00	10 - 37	5BE-14788-00	12 - 18	4MX-14948-06	10 - 19	5TJ-15560-20	16 - 1
1WG-12118-00	3 - 10		6 - 6	5JG-14346-00	10 - 57	5TJ-14799-00	12 - 13		10 - 19	5UM-15570-00	16 - 7
33M-12119-00	3 - 11	2S2-12481-00	6 - 12	5TA-14371-00	10 - 36	5UM-14803-00	11 - 6	4MX-14948-07	10 - 19	5VY-15586-00	16 - 8
4SV-12119-00	3 - 12	1C3-12482-00	6 - 16	5JG-14379-00	10 - 42	5TJ-14815-00	11 - 2	4MX-14948-08	10 - 19	2S2-15601-00	15 - 1
5TA-12121-00	3 - 3	2S2-12482-00	6 - 19	2S2-14388-00	10 - 8	5TJ-14834-E0	11 - 7	4MX-14948-09	10 - 19	2S2-15620-01	15 - 18
3GM-12126-00	3 - 4	5BE-12564-00	5 - 12	4MX-14392-00	10 - 26	5TJ-14871-10	11 - 1	4JT-1494F-01	10 - 22	5XD-15621-00	15 - 19
3FV-12153-10	3 - 14	2S2-12576-00	6 - 15	5UM-14401-E0	9 - 12	5TJ-14881-10	11 - 4	4JT-1494F-03	10 - 22	5TA-15651-00	15 - 15
3LD-12168-00	3 - 13	2S2-12578-00	6 - 17	5UM-14417-E0	9 - 26	5TJ-14882-10	11 - 10	4JT-1494F-05	10 - 22	5GR-15664-00	15 - 8
3LD-12168-20	3 - 13	5TJ-12579-E0	6 - 18	5TJ-14419-00	9 - 32	5TJ-14916-91	10 - 12	4JT-1494F-07	10 - 22	5SG-15668-00	15 - 11
3LD-12168-40	3 - 13	583-13113-00	14 - 32	5UM-1441A-E0	9 - 34	5TJ-14916-9M	10 - 12	4JT-1494F-09	10 - 22	2S2-15671-00	15 - 4
3LD-12168-60	3 - 13	353-13115-01	1 - 2	5UM-1441G-E0	9 - 19	5TJ-14916-9N	10 - 12	3TJ-1494F-11	10 - 20	214-15686-00	15 - 12
3LD-12168-80	3 - 13	2S2-13300-10	7 - 1	5UM-14437-E0	9 - 23	5TJ-14916-9P	10 - 12	4JT-1494F-11	10 - 22	2S2-16111-60	17 - 1
3LD-12168-A0	3 - 13	5TA-13320-00	7 - 2	5UM-1443A-E0	9 - 25	5TJ-14916-9R	10 - 12	3TJ-1494F-12	10 - 20	5XD-16150-10	17 - 4
3LD-12168-F0	3 - 13	2S2-13341-00	7 - 9	5UM-1443B-L0	9 - 33	5TJ-14916-9S	10 - 12	3TJ-1494F-13	10 - 20	5XD-16154-00	17 - 11
3LD-12168-H1	3 - 13	2S2-13342-00	7 - 7	5BF-1443E-00	9 - 28	5TJ-14916-9T	10 - 12	4JT-1494F-13	10 - 22	5TA-16321-00	17 - 8
3LD-12168-K1	3 - 13	5BE-13411-00	7 - 13	5NY-14442-00	9 - 16	5TJ-14916-A1	10 - 12	3TJ-1494F-14	10 - 20	1TA-16325-00	17 - 12

NUMERICAL INDEX

PART NO.	REF. NO.	PART NO.	REF. NO.	PART NO.	REF. NO.	PART NO.	REF. NO.	PART NO.	REF. NO.	PART NO.	REF. NO.
4X7-16325-00	17 - 7	2S2-21417-00	21 - 30	2S2-22128-70	24 - 13	5XE-23111-L0	27 - 39	3SP-23356-L0	27 - 50	1C3-25388-H0	32 - 20
5JG-16351-00	17 - 6	2S2-21425-70	21 - 23	1C3-22141-10	24 - 17	5XE-23117-L0	27 - 19	5XE-23364-00	45 - 3	1C3-25389-H0	32 - 21
5JG-16356-00	17 - 15	2S2-21426-70	21 - 24	2S2-22151-70	24 - 10		27 - 40	5TJ-23389-80	26 - 17	3JE-25394-00	32 - 13
2S2-16357-00	17 - 20	5UM-21447-E0	21 - 2	5UN-22176-00	25 - 13	5TJ-23120-C0	27 - 3	5XE-23393-L0	27 - 12	5SF-25394-00	30 - 10
5TA-16371-10	17 - 5	1C3-21448-10	21 - 3	30X-22178-00	21 - 8	5XE-23125-L0	27 - 5		27 - 33	1C3-25447-00	32 - 15
5TJ-16381-20	17 - 21	5XC-21456-90	21 - 33	3JD-22178-20	21 - 13		27 - 26	5TJ-2339E-00	41 - 11	1C3-25448-00	32 - 15
5TJ-17121-20	18 - 9	5UM-2147A-E0	21 - 34	5XC-2217A-90	24 - 20	3JD-2312G-L0	27 - 21	4EW-23416-00	26 - 3	5GS-25448-50	32 - 15
5TJ-17131-20	18 - 6	5TJ-21485-E0	21 - 37	5XC-2217F-90	24 - 26		27 - 42	5UM-23435-E1	26 - 6	1C3-25449-00	32 - 15
5TJ-17141-20	18 - 7	5UM-21486-E0	21 - 36	4V4-22184-00	21 - 9	5TJ-23136-C0	27 - 2	5XC-23441-90	26 - 9	1C3-25450-00	32 - 15
5TJ-17151-20	18 - 3	1C3-21511-51	22 - 1	5MV-22184-00	25 - 14		27 - 23	5UM-23442-E0	26 - 10	5TJ-25450-80	32 - 15
5TJ-17211-20	18 - 14	3XJ-2151H-A1	22 - 22	5UM-22199-E0	24 - 12	5TJ-23141-00	45 - 2	5XC-23466-L0	27 - 51		32 - 15
5TJ-17221-20	18 - 25	3XJ-2151H-B1	22 - 23	5TJ-22201-20	25 - 2	5TJ-23141-10	45 - 2	5XC-23467-L0	27 - 52	1C3-25451-00	32 - 15
5TJ-17231-20	18 - 20	4XL-2153A-10	27 - 47	5TJ-22201-F0	25 - 2	5TJ-23141-20	45 - 2	5TJ-23525-C0	27 - 45	1C3-25452-00	32 - 15
5TJ-17241-20	18 - 23		27 - 49	5TJ-22201-G0	25 - 2	5TJ-23141-30	45 - 2	5UM-23591-E0	40 - 15	5TJ-25452-80	32 - 15
5TJ-17251-20	18 - 17	5UM-2153E-00	22 - 24	5TJ-22210-20	25 - 1	5TJ-23141-40	45 - 2	5UM-24110-E1	28 - 1	5CG-25715-00	35 - 10
2S2-17402-00	18 - 13	4ES-2153E-01	22 - 4	5TJ-22210-F0	25 - 1	5TJ-23141-60	45 - 2	5TJ-24110-J0	28 - 1		37 - 9
5TJ-17411-20	18 - 2	5PA-21568-01	22 - 25	5TJ-22210-G0	25 - 1	5TJ-23141-L0	27 - 17	4EW-2412F-00	28 - 16	1C3-25718-50	33 - 18
5NG-17460-00	18 - 31	5UM-21610-E0	22 - 8	5UN-22212-00	45 - 1		27 - 38	5XE-24144-00	28 - 6	1C3-2580T-00	31 - 3
5TJ-17460-00	18 - 31	5XE-21635-10	22 - 9	5UN-22212-10	45 - 1	5XE-23142-L0	27 - 11	3ME-2415E-01	22 - 26	1C3-2580W-72	33 - 3
2S2-17466-00	13 - 9	5TA-21642-00	22 - 17	5UN-22212-20	45 - 1		27 - 32	3FB-2415E-02	22 - 5	2S2-2581T-70	31 - 1
	13 - 9	5TJ-2165C-10	9 - 47	5UN-22212-30	45 - 1	5XE-23144-L0	27 - 9	3FB-2415E-12	22 - 6	5UN-25827-60	33 - 10
5TJ-17466-00	13 - 9	3RV-21668-A0	24 - 36	5UN-22212-40	45 - 1		27 - 30	3PT-2416E-10	22 - 7	5UN-25828-60	33 - 9
2S2-17471-00	18 - 34	3RV-21668-B0	24 - 37	5UN-22212-50	45 - 1	1C3-23145-L0	27 - 7	5UM-24181-E0	28 - 18	2S2-2582W-70	33 - 1
2S2-18101-00	20 - 1	5UN-2167A-10	23 - 2	5UN-22212-60	25 - 17		27 - 28	5XC-24182-90	28 - 25	5MV-25833-00	35 - 16
5XC-18110-00	20 - 7	5TJ-2167B-10	23 - 11	5UN-22212-70	45 - 1	5XE-23146-L0	27 - 6	5XC-24183-90	28 - 26	17D-2583V-00	37 - 1
5MW-18122-01	20 - 2	5UM-21711-E0	23 - 1	3SP-22213-00	25 - 4		27 - 27	3JD-24186-00	28 - 11	5DH-25849-00	31 - 15
2S2-18140-10	19 - 6	5UM-21717-E0	23 - 3	5XE-22214-00	25 - 18	5NY-23147-L0	27 - 15	5XC-2419A-90	28 - 12	5MV-25852-01	35 - 8
5TJ-18172-00	20 - 15	5XC-21719-90	23 - 8	5MV-22224-00	25 - 9		27 - 36	5TJ-24311-E0	28 - 21	5UN-25852-50	37 - 5
3XJ-18173-10	20 - 10	5UM-21721-E0	23 - 6	4JX-22226-00	25 - 7	1C3-2314F-M0	27 - 20	5TJ-24311-J0	28 - 21	5XE-25853-00	35 - 11
3XJ-18178-00	20 - 11	2S2-2172A-80	23 - 21	3SP-22234-00	25 - 3		27 - 41	5XC-24339-90	28 - 14	5UN-25854-00	37 - 7
3XJ-18182-00	20 - 12	5TJ-2172A-E0	23 - 17	5NY-22241-00	25 - 22	5XE-23153-L0	27 - 8	3XJ-24380-00	28 - 4	5XE-25854-00	35 - 7
3XJ-18184-00	20 - 14	5UM-2172S-E0	23 - 9	5XE-22242-00	25 - 19		27 - 29	5UM-24500-E0	28 - 19	5UN-2585B-00	37 - 6
2S2-18185-00	20 - 17	5UM-21730-E0	23 - 14	5MV-22253-00	25 - 15	4SS-23158-L0	27 - 16	1P6-24512-00	28 - 20	5CG-2585G-00	37 - 10
34P-18501-00	19 - 10	5TJ-2173L-10	23 - 15	1C3-22253-50	25 - 10		27 - 37	5NY-24610-00	28 - 2	5MV-25867-00	35 - 15
2S2-18502-00	19 - 11	5UM-2173S-E0	23 - 10	4AA-22259-40	25 - 5	1C3-2315H-10	27 - 48	5UM-2470F-E0	29 - 2	5NY-25868-00	35 - 6
34P-18503-00	19 - 12	5UM-21740-E0	23 - 18	4AA-22259-60	25 - 5	5TJ-2315J-C0	27 - 46	5UM-24710-E0	29 - 1	5TJ-25872-80	35 - 1
5NL-18541-00	19 - 1	5UM-2174A-E0	23 - 7	1P8-22355-00	24 - 3	5TJ-2316A-F0	27 - 13	5UM-24723-E0	29 - 3	5XC-25873-L0	37 - 12
278-18542-00	19 - 3	5TJ-2174L-10	23 - 19	4EW-22474-00	25 - 12		27 - 34	5NY-25104-00	30 - 6	1C3-25875-50	31 - 17
2S2-18562-00	13 - 18	5UM-2174T-E0	22 - 10	3JE-22475-00	25 - 11	5UM-23170-E0	27 - 10	5TJ-2510C-80	30 - 12	1C3-25876-50	37 - 17
5TJ-21101-E0	21 - 1	2TK-21757-00	9 - 36	5NY-22475-00	25 - 16		27 - 31	5NG-25111-50	30 - 1	1C3-25886-50	37 - 15
5PA-2118K-00	22 - 20	5TJ-21757-00	9 - 37	5UN-22898-60	33 - 11	5XE-23171-L0	27 - 4	5NY-25117-00	30 - 3	5MV-2589F-00	35 - 13
5PA-2118K-10	22 - 21	4XV-2177L-01	9 - 21	1C3-22969-90	24 - 11		27 - 25	1C3-25181-10	30 - 11	5UN-25914-00	33 - 16
5UM-21190-E0	21 - 5	5UM-21860-E0	23 - 22	5TJ-23102-E0	27 - 1	5DH-23183-00	25 - 8	5GS-25304-00	32 - 9	5DH-25914-50	33 - 14
1C3-21244-10	28 - 28	26H-21874-00	23 - 24	5TJ-23102-F0	27 - 1	509-23184-L0	25 - 6	5TJ-2530S-80	32 - 19	3SP-25914-51	31 - 12
5UM-21268-E0	21 - 41	26H-21875-00	23 - 23	5TJ-23103-E0	27 - 22	5NY-23188-L0	27 - 14	5ET-25311-00	32 - 1	5DH-25916-00	31 - 10
5UM-21288-E0	44 - 19	1C3-22110-90	24 - 1	5TJ-23103-F0	27 - 22		27 - 35	5ET-25317-00	32 - 2		33 - 13
1C3-2135F-00	24 - 34	5XC-22121-91	24 - 30	5TJ-23110-C0	27 - 24	5TJ-2331E-80	26 - 15	4XM-25364-00	32 - 14	3JD-25917-00	31 - 13
1C3-2139R-00	24 - 35	1C3-22122-00	24 - 31	5XE-23111-L0	27 - 18	5TJ-23340-M0	27 - 43	1C3-25381-90	32 - 24		33 - 15

NUMERICAL INDEX

PART NO.	REF. NO.	PART NO.	REF. NO.	PART NO.	REF. NO.	PART NO.	REF. NO.	PART NO.	REF. NO.	PART NO.	REF. NO.
5DH-25919-00	31 - 6	5UM-81952-E0	44 - 30	5XC-85885-00	10 - 46	90105-08154	26 - 13	90179-10658	21 - 28	90201-20685	15 - 2
5DH-25919-50	33 - 6	5UM-81960-E0	44 - 18	5NY-W0041-00	35 - 5	90105-08156	21 - 6	90179-12657	38 - 6		15 - 16
8CR-25924-00	33 - 12	4WA-81980-00	44 - 17	5UN-W0042-50	37 - 2	90105-08307	12 - 19	90179-16011	30 - 13	90201-21014	24 - 25
3SP-25926-51	31 - 11	5TJ-81980-00	44 - 16	5MV-W0045-01	31 - 8		21 - 7	90179-20001	18 - 33	90201-24016	26 - 8
5DH-25933-00	31 - 9	5TJ-82100-01	44 - 21	1C3-W0046-B0	33 - 8	90105-10163	1 - 15	90179-20009	17 - 3	90201-253K0	18 - 4
1UY-25937-51	31 - 14	5TJ-82115-00	44 - 24	3JD-W0047-00	31 - 5	90105-10176	21 - 27	90179-28013	26 - 4		18 - 21
	33 - 17	5TJ-82116-E0	44 - 25	5UN-W0047-50	33 - 5	90105-10189	21 - 22	90183-060A6	6 - 4	90201-286K9	26 - 5
5XC-26111-L0	34 - 1	5SL-82119-10	44 - 28	1UY-W0048-50	31 - 7	90105-10191	21 - 25		6 - 8	90202-05193	28 - 23
5XC-26124-90	34 - 11	8CY-82131-00	44 - 23		33 - 7	90105-10193	21 - 19	90185-08008	32 - 17	90202-08045	10 - 5
5XC-26143-L0	34 - 12	42X-82151-00	44 - 27	5UN-W0057-00	31 - 4	90109-06034	43 - 3	90185-08009	21 - 17	90206-06090	12 - 5
5TJ-26240-C0	34 - 3	5UM-82176-E0	44 - 22	5UN-W0057-50	33 - 4	90109-06198	19 - 8	90185-10012	25 - 23	90208-25045	17 - 2
4GY-26241-00	34 - 2	5TA-82310-10	44 - 3	5XE-W2587-10	35 - 4	90109-06245	9 - 41	90185-10018	36 - 23	90209-16011	24 - 24
5BE-26281-00	34 - 4	5UM-8235Y-E0	44 - 33	90101-06041	20 - 16	90109-08078	32 - 16	90185-14010	24 - 33	90209-21332	18 - 10
5BE-26282-00	34 - 5	5UM-82510-E1	44 - 32	90101-06044	15 - 13	90109-10026	36 - 19	90185-16002	24 - 18		18 - 19
5SF-26287-10	34 - 7	5TJ-82540-01	44 - 4	90101-08006	32 - 22	90110-05038	9 - 10	90185-20002	32 - 25	90209-26348	18 - 24
5UM-26302-E0	34 - 8	5TJ-82590-E0	44 - 15	90105-05016	26 - 16	90110-05041	12 - 12	90201-05021	40 - 3	90215-10009	2 - 19
5UM-26334-E0	43 - 12	5TJ-82590-F0	44 - 15	90105-06027	1 - 5	90110-06228	8 - 5	90201-06013	19 - 9	90215-14287	2 - 13
5TJ-26335-E0	34 - 9	5TJ-82911-80	43 - 1	90105-06064	23 - 16	90110-06248	38 - 5	90201-06032	22 - 13	90215-20005	17 - 13
5HD-26337-00	43 - 5	5XD-82913-00	43 - 10		23 - 20	90110-08087	15 - 24	90201-06084	22 - 18	90215-21003	18 - 32
5TA-26339-00	43 - 17	5TJ-82917-02	43 - 7		41 - 10	90110-08097	12 - 7	90201-06570	28 - 10	90240-08120	36 - 6
1C3-26342-50	34 - 10	5XD-82946-00	43 - 9	90105-06081	13 - 19	90111-06116	37 - 11	90201-06571	6 - 28	90240-10004	36 - 11
5NY-26372-00	35 - 17	5TJ-83500-F0	40 - 1		18 - 35	90116-08022	1 - 11		22 - 15	90249-05004	9 - 39
5TJ-26372-80	43 - 8	5TJ-83500-G0	40 - 1	90105-06100	22 - 12	90119-06146	23 - 25	90201-08043	21 - 18	90249-05005	9 - 38
2S2-27200-10	36 - 1	5UM-83519-E0	40 - 5	90105-06103	23 - 4	90119-06147	22 - 3	90201-08044	36 - 7	90280-03006	2 - 20
5UN-27217-00	37 - 8	5UM-83595-E0	40 - 13		23 - 12	90119-06166	21 - 35	90201-08045	21 - 10	90282-05034	2 - 17
1C3-27217-10	36 - 2	5TJ-83755-C0	40 - 7	90105-06104	24 - 14	90119-08095	23 - 5	90201-08047	15 - 25	90338-07043	9 - 22
5UN-27218-00	37 - 3	5TJ-8375E-C0	40 - 11	90105-06105	11 - 9		23 - 13	90201-08048	32 - 18	90340-12007	1 - 6
5UN-27222-00	37 - 4	5TJ-8375F-C0	40 - 9		24 - 16	90149-05024	38 - 4	90201-08061	12 - 21	90340-14003	14 - 4
5UM-27311-E0	36 - 16	5TJ-83912-80	43 - 2	90105-06106	22 - 14	90149-05162	43 - 16	90201-08410	10 - 44	90340-27003	14 - 2
5UM-27315-E0	36 - 22	1C3-83922-50	35 - 12	90105-06107	11 - 8	90149-06068	7 - 8	90201-08512	5 - 3	90387-06009	22 - 16
5XC-27411-M1	36 - 9	5TA-83941-00	43 - 11		26 - 18	90149-06074	13 - 16	90201-10025	1 - 16	90387-06065	6 - 26
5XC-27421-M1	36 - 10	5HD-83951-00	43 - 6		28 - 8	90149-06083	2 - 15	90201-10032	36 - 15		28 - 15
1C3-27491-50	33 - 20	5UM-83976-E1	43 - 18		33 - 21	90149-06108	28 - 24	90201-10045	21 - 21	90387-06090	22 - 2
5XC-28116-00	21 - 40	5UM-83976-F1	43 - 19		33 - 2	90149-10031	21 - 4		21 - 26		28 - 13
5TA-2814F-00	21 - 39	5LP-84126-10	43 - 4		33 - 2	90151-04003	24 - 2		21 - 29	90387-06104	26 - 19
5ET-28166-10	21 - 38	5UM-84310-E1	41 - 1	90105-06108	33 - 2	90151-06051	31 - 2		36 - 20	90387-08041	21 - 11
5UM-2831V-E0	26 - 14	5VM-84314-00	41 - 2	90105-06110	33 - 19	90151-06071	13 - 15	90201-105A8	16 - 2	90387-08081	12 - 17
3FV-28386-00	9 - 35	5UM-84330-E0	41 - 4		40 - 6	90152-06010	15 - 22	90201-12020	38 - 7	90387-086N4	21 - 15
5TJ-81410-50	38 - 1	5BF-84334-00	41 - 8		44 - 20	90154-05022	44 - 6	90201-12166	7 - 11	90387-1003G	36 - 21
5TJ-81450-30	38 - 2	5UM-84340-E1	41 - 3	90105-06111	6 - 27	90157-04005	41 - 6	90201-125L6	17 - 17	90387-124F4	20 - 3
5TJ-81528-00	38 - 3	5UM-84710-E0	42 - 1		28 - 9	90159-06092	17 - 10	90201-127E1	20 - 5	90387-14009	24 - 29
5TJ-81801-00	39 - 2	5UM-84716-E0	42 - 4		33 - 22	90170-10405	2 - 18	90201-14020	24 - 32	90387-16025	24 - 23
5TJ-81828-01	39 - 7	5UM-84736-E0	42 - 2	90105-06127	22 - 11	90170-14171	2 - 12	90201-15701	14 - 19	90387-18004	24 - 9
5TJ-8183G-30	39 - 6	5UM-84737-E0	42 - 3	90105-08133	21 - 16	90170-20327	17 - 14	90201-16018	24 - 19	90387-18007	13 - 22
50W-81846-M1	39 - 4	5TJ-85540-E0	44 - 1	90105-08134	27 - 44	90170-24003	26 - 7	90201-162H4	15 - 10	90387-18012	24 - 8
5TJ-81890-30	39 - 1	5TJ-85540-F0	44 - 1	90105-08137	12 - 20	90179-06028	24 - 15	90201-167P7	15 - 6	90387-20028	18 - 15
5TJ-81940-12	44 - 26	5TJ-85540-L0	44 - 1		31 - 16	90179-08019	32 - 23	90201-20020	32 - 26	90387-21005	18 - 8
5UM-81950-E0	44 - 31	5UM-85546-E0	44 - 2	90105-08143	21 - 31	90179-10658	21 - 20	90201-203E7	18 - 16	90387-2513F	18 - 29

NUMERICAL INDEX

PART NO.	REF. NO.	PART NO.	REF. NO.	PART NO.	REF. NO.	PART NO.	REF. NO.	PART NO.	REF. NO.	PART NO.	REF. NO.
90387-28012	18 - 26	90467-17089	11 - 12	93102-12224	17 - 23	93317-11287	17 - 22	95022-06030	5 - 11	99530-10114	13 - 20
90401-10172	35 - 3	90468-16001	36 - 8		20 - 9	93317-22262	24 - 4		7 - 14	99530-14016	13 - 4
	37 - 13	90480-12020	41 - 9	93102-20108	15 - 14	93332-00068	26 - 2		14 - 12		13 - 23
90413-14001	9 - 44	90480-14012	40 - 2	93102-26468	30 - 4	93332-00081	26 - 1		14 - 25	9Y58A-76113	32 - 27
90430-06014	1 - 9	90480-15528	6 - 25	93102-32480	18 - 28	93340-21505	17 - 16		14 - 29		
	4 - 8	90480-18549	28 - 7	93105-47007	40 - 8	93342-22217	24 - 5	95022-06035	1 - 10		
	5 - 10	90501-043E0	14 - 34	93106-22002	24 - 6	93410-20038	15 - 3		1 - 27		
	13 - 31	90501-052G5	20 - 13	93106-30001	32 - 5	93420-18082	2 - 24	95022-06040	14 - 11		
90430-08119	13 - 26	90501-06022	19 - 4	93106-30045	32 - 6	93440-10085	17 - 18		14 - 24		
90430-10005	35 - 2	90501-120A3	41 - 7	93109-11073	5 - 4	93440-10153	7 - 4		14 - 30		
	37 - 14	90501-147A5	15 - 20	93109-22019	24 - 28	93440-25084	18 - 5	95022-06080	14 - 31		
90430-10188	13 - 12	90501-160A2	15 - 5	93109-25001	24 - 22		18 - 18	95022-08040	21 - 12		
90445-082K4	11 - 13	90501-237L0	17 - 9	93109-28043	24 - 7	93440-28062	18 - 22	95022-10016	13 - 11		
90445-09027	28 - 3	90506-16007	36 - 5	93210-07135	8 - 4	93440-41178	4 - 3	95602-05100	43 - 15		
90445-09220	28 - 3	90506-30005	36 - 17	93210-08003	14 - 10	93503-08007	14 - 33	95602-10200	25 - 20		
90445-09251	28 - 5	90508-26021	19 - 7	93210-09165	13 - 28	93507-32009	15 - 21		26 - 12		
90445-14009	7 - 16	90508-28015	36 - 13	93210-10197	13 - 21	93511-32027	17 - 19	95701-06500	35 - 14		
90445-217G3	36 - 18	90508-28018	36 - 14	93210-11073	36 - 3	93603-16219	7 - 3	95702-05500	40 - 4		
90450-17001	7 - 17	90508-29021	20 - 4	93210-14369	14 - 5	93604-10011	5 - 9	95702-06500	27 - 53		
90450-22001	6 - 24	90508-305B0	15 - 9	93210-16500	6 - 14	93608-33002	20 - 6	95702-08500	1 - 12		
90450-25001	6 - 23	91312-06012	6 - 13		6 - 21	93612-16254	1 - 26	95822-08016	13 - 25		
90450-28001	6 - 22	91312-06020	8 - 7	93210-17570	15 - 23	9383E-13233	18 - 31	97002-05016	43 - 13		
90450-57010	9 - 4		9 - 3	93210-19123	14 - 7		18 - 31	97602-04110	10 - 65		
90450-61002	9 - 11	91312-06030	7 - 6	93210-19758	5 - 13	9383E-14215	18 - 31	97702-40010	40 - 10		
90461-10136	13 - 29		13 - 24	93210-21001	44 - 5	94108-21015	30 - 7		42 - 7		
90464-06004	44 - 34	91312-06050	13 - 5	93210-22164	18 - 30	94109-21009	30 - 7	97702-50016	42 - 5		
90464-11M18	42 - 6	91312-06060	13 - 6	93210-25711	39 - 5	94111-18012	32 - 10	97702-50516	9 - 24		
90464-13073	44 - 10	91312-06065	8 - 6	93210-27370	14 - 3	94113-18015	32 - 10		9 - 27		
90464-13077	44 - 7	91312-06080	13 - 7	93210-44678	39 - 3	94212-18188	32 - 11		9 - 31		
90464-15152	44 - 8	91314-06016	11 - 3	93210-47675	8 - 3	94213-18012	32 - 11		41 - 5		
90464-15195	44 - 12	91316-04012	10 - 3	93210-58346	14 - 15	94227-21101	30 - 8	97702-60016	22 - 19		
	44 - 12	91402-20012	36 - 4	93300-60839	21 - 14	94309-18146	32 - 12	98502-05010	37 - 16		
90464-16061	44 - 11	91402-25015	36 - 12	93304-20310	2 - 10	94309-21161	30 - 9	98502-05020	34 - 6		
90464-23041	44 - 14	91808-16023	1 - 7	93306-00105	5 - 6	94416-21018	30 - 5	98502-06025	13 - 10		
90465-13152	44 - 13	91812-16001	14 - 23	93306-00426	18 - 12	94421-18008	32 - 8	98702-06025	28 - 17		
90465-13275	28 - 27	91A20-05140	6 - 10	93306-00431	18 - 11	94591-57118	4 - 4	98706-04012	35 - 9		
	44 - 9	92012-05008	12 - 14	93306-07202	32 - 4	94681-76021	32 - 28	98980-06008	12 - 4		
90467-07138	11 - 14		40 - 12	93306-20532	18 - 1	94701-00411	1 - 13	99002-04600	9 - 40		
90467-09006	11 - 15	92012-05012	43 - 14	93306-205A5	18 - 27	95022-06008	44 - 29	99009-12400	7 - 10		
90467-090A2	6 - 11	92012-06010	6 - 3	93306-27212	32 - 3	95022-06010	1 - 8	99009-16400	15 - 7		
	23 - 27		6 - 7	93306-30633	2 - 7	95022-06012	6 - 20	99009-20400	15 - 17		
90467-100A1	28 - 22	92012-06012	40 - 16	93306-80501	19 - 5		13 - 30	99009-20500	17 - 24		
90467-140A4	11 - 11	92902-06600	40 - 17	93306-90409	30 - 2	95022-06016	13 - 33	99009-22500	14 - 20		
90467-16063	11 - 5	92902-08200	21 - 32	93306-90509	19 - 2		14 - 16	99009-45500	32 - 7		
90467-160A4	1 - 22	92902-10200	25 - 21	93310-212R6	16 - 3	95022-06020	14 - 13	99530-08012	7 - 5		
	9 - 45		26 - 11	93310-63417	2 - 5		20 - 8	99530-08016	14 - 9		
90467-17089	9 - 29	93101-14164	14 - 18	93315-32166	24 - 21	95022-06025	4 - 7		14 - 28		
	9 - 46	93102-12106	5 - 5	93315-32269	24 - 27		39 - 8	99530-10114	7 - 15		